

# ***MLT4060MVD***

## ***Light Tower Parts Manual***

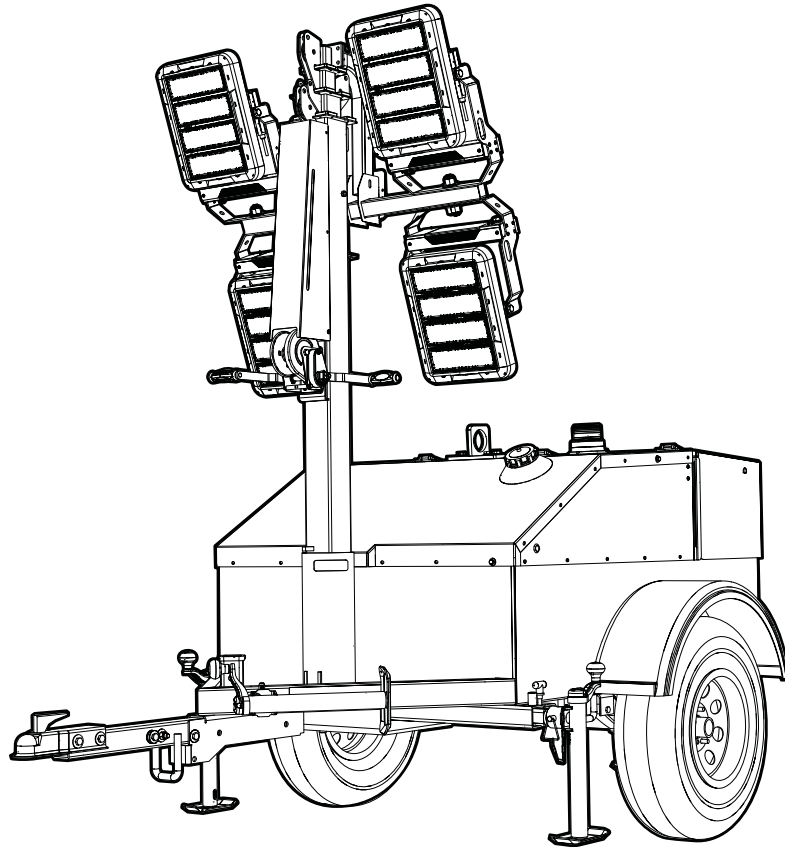

02622

MODEL NUMBER: \_\_\_\_\_

SERIAL NUMBER: \_\_\_\_\_

DATE PURCHASED: \_\_\_\_\_

***SAVE THIS MANUAL FOR FUTURE REFERENCE***

 **WARNING**

**CANCER AND REPRODUCTIVE HARM**

[www.P65Warnings.ca.gov](http://www.P65Warnings.ca.gov).

(000393a)

 **WARNING**

Breathing diesel engine exhaust exposes you to chemicals known to the State of California to cause cancer and birth defects or other reproductive harm.

- Always start and operate the engine in a well-ventilated area.
- If in an enclosed area, vent the exhaust to the outside.
- Do not modify or tamper with the exhaust system.
- Do not idle the engine except as necessary.

For more information go to

[www.P65Warnings.ca.gov/diesel](http://www.P65Warnings.ca.gov/diesel).

(000394)

# Introduction

This parts manual was prepared based on the information available at the time of publication and is subject to change without notice. Generac Mobile Products reserves the right to change parts at any time. To check whether a revised parts manual is available, contact Generac Mobile Products.

DO NOT MODIFY or use this equipment for any application other than which it was designed for. To keep your equipment fully operational, it is suggested you maintain a stock of commonly used maintenance or service parts. A recommended spare parts list can be found in the back of this manual. To order service parts, please go to [www.generacmobileproducts.com](http://www.generacmobileproducts.com) or call Generac Mobile Products.



## **WARNING**

Consult Manual. Read and understand manual completely before using product. Failure to completely understand manual and product could result in death or serious injury.

(000100a)

---

## **WARNING**

Environmental Hazard. Always recycle batteries at an official recycling center in accordance with all local laws and regulations. Failure to do so could result in environmental damage, death, or serious injury.

(000228)

## **GENERAC MOBILE PRODUCTS LLC**

**215 Power Drive • Berlin, WI 54923 U.S.A.**

**Phone: 920-361-4442**

**FAX: 920-361-4416**

**Toll Free: 1-800-926-9768**

**[www.generacmobileproducts.com](http://www.generacmobileproducts.com)**

**For technical or parts QUESTIONS, contact Generac Mobile Products Technical Service at 1-800-926-9768.**

Engine Make: \_\_\_\_\_

Engine Serial Number: \_\_\_\_\_

Engine Model Number: \_\_\_\_\_

This Page Intentionally Left Blank

# Table of Contents

Introduction .....	iii
Parts Manual Instructions .....	1
Unit Decals - Exterior .....	2
Unit Decals - Interior .....	4
Mast, Junction Box and Lights to Unit .....	6
Light Assembly .....	8
Mast Junction Box Assembly - Hard Wired Lights .....	10
Diffused Lighting (If Equipped) .....	12
Mast Assembly .....	14
Mast Assembly - Bottom Post - Manual Winch .....	16
Mast Assembly - Bottom Post - Electric Winch .....	18
Rear Hood to Unit .....	20
Rear Hood Assembly .....	22
Front and Side Panels to Unit .....	24
Control Box Assembly (1 of 2) .....	26
Control Box Assembly (2 of 2) .....	28
Cooling System Assembly .....	30
Engine and Generator to Unit .....	32
Engine Assembly - Right Side .....	34
Engine Assembly - Left Side .....	36
Generator Assembly .....	38
Block Heater (If equipped) .....	40
Fuel Tank To Unit .....	43
Trailer Assembly .....	44
Axle Assembly .....	46
Recommended Spare Parts - Engine and Service Kits .....	48
Recommended Spare Parts - Electrical .....	50
Recommended Spare Parts - Misc .....	52

This Page Intentionally Left Blank

# Parts Manual Instructions

Product illustrations are only representations. Products supplied may vary from the illustrations in this parts manual. Parts not shown in the illustration are indicated by a double dash (--) in the item column.

Please be prepared to provide the following information when ordering replacement parts: model number, serial number (on unit serial tag), part number, purchase order number (if applicable), shipping address, shipping method.

Refer to the illustration below to locate the unit ID tag and Vehicle Identification Number (VIN) tag on the unit. Important information, such as the unit serial number, model number, VIN and tire loading information are found on these tags. Record the information from these tags so it is available if the tags are lost or damaged. When ordering parts or requesting assistance, you may be asked to provide this information.

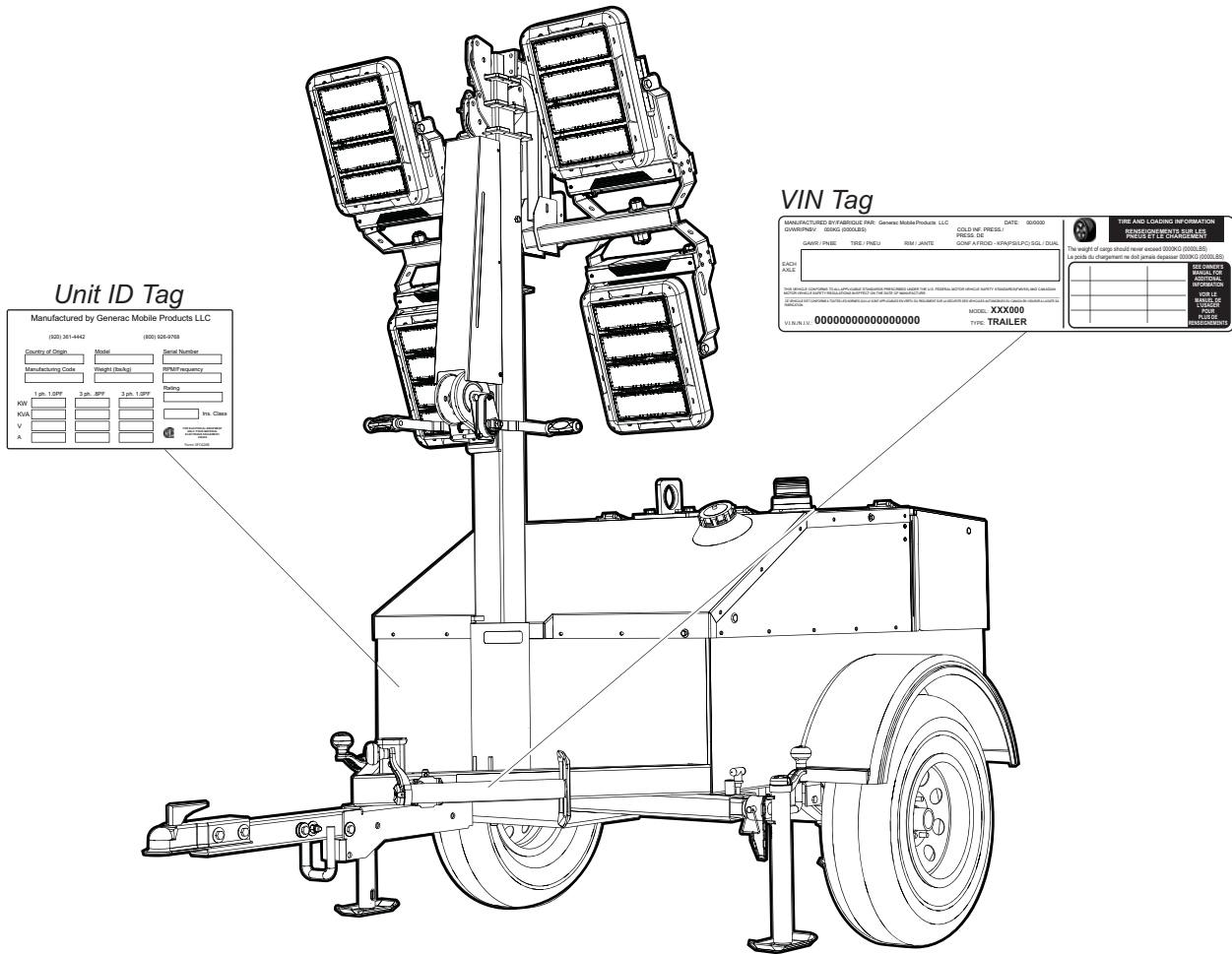

02603

# UNIT DECALS - EXTERIOR

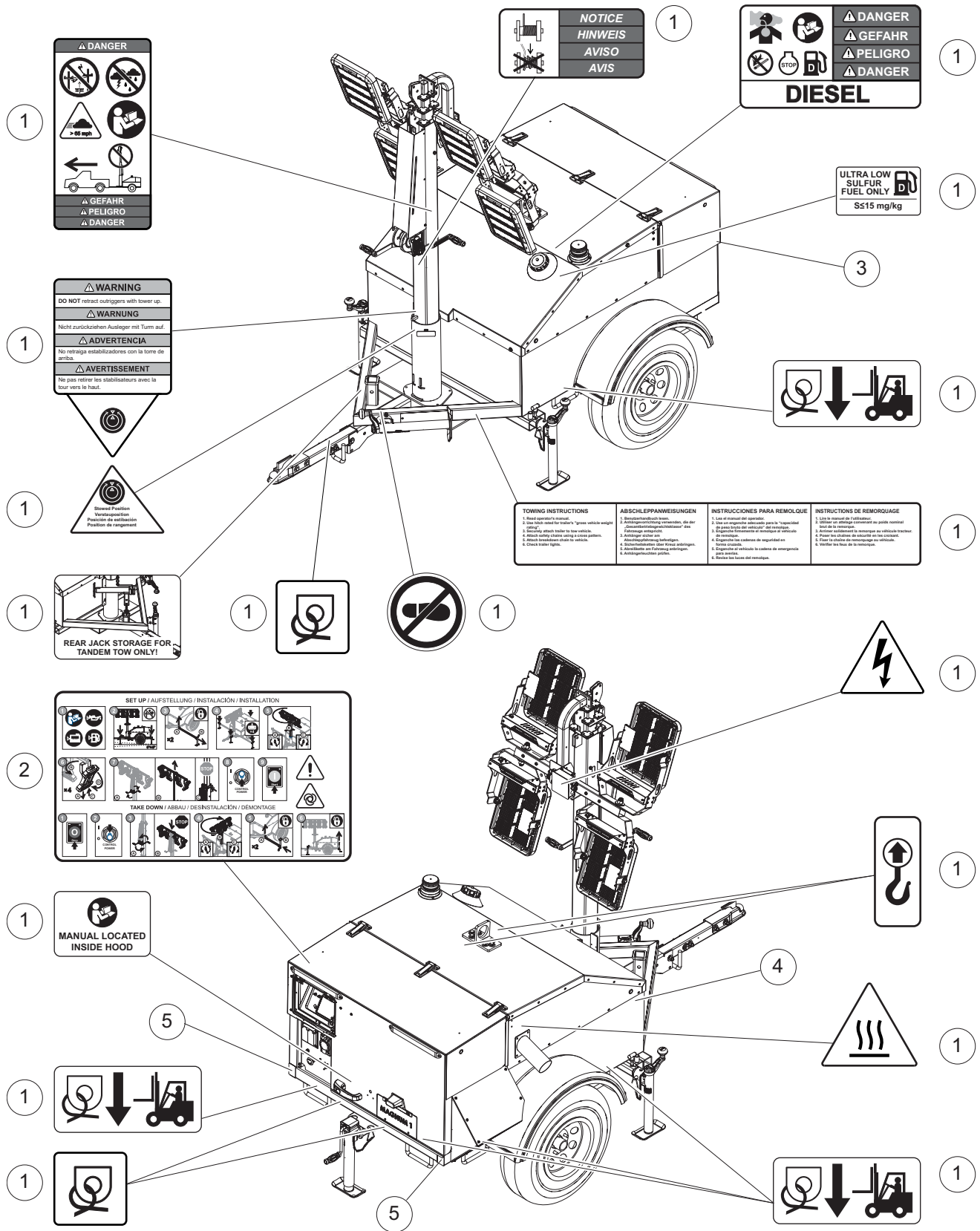

02604



## UNIT DECALS - EXTERIOR

---

Item	Part No.	Qty	Description	Notes
1	73119	1	Decals, safety MLT4060MVD	
2	10000034381	1	Decal, operation - MLT4060MVD	
--	10000034390	1	Decal, operation, EW - MLT4060MVD	Electric Winch only
3	72149	1	Reflector, 4.250 x .750 - red	2 per set
4	72150	1	Reflector, 4.250 x .750 - yellow	2 per set
5	72132	2	Decal, rear reflector 2.0 x 2.0	2 per set

# UNIT DECALS - INTERIOR

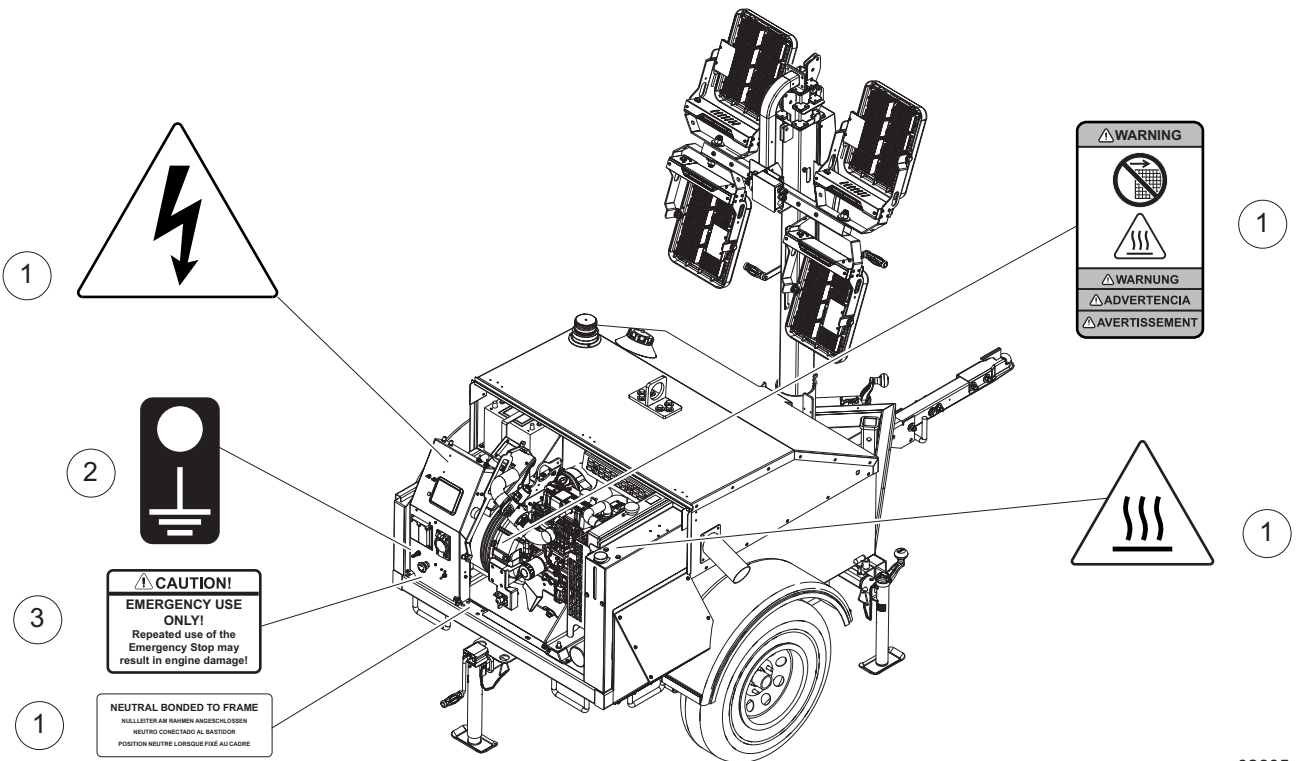
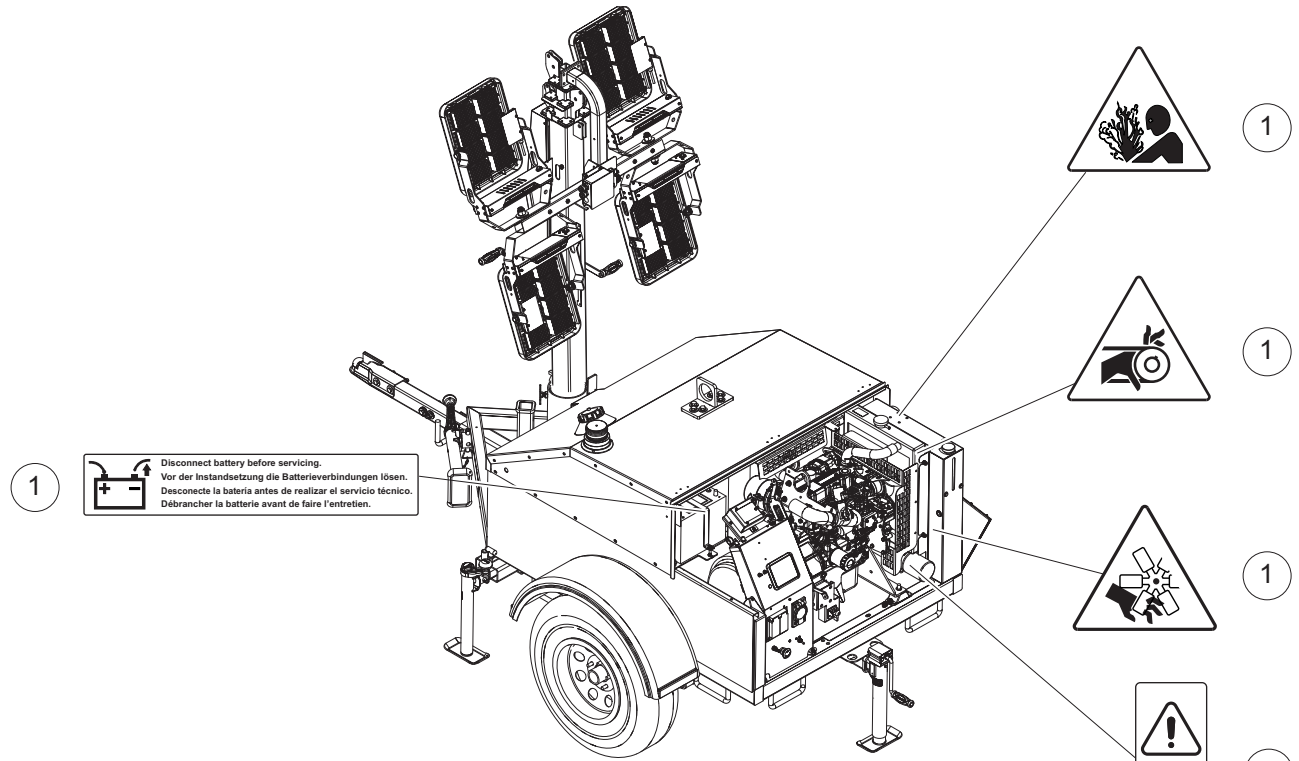

02605

## UNIT DECALS - INTERIOR

---

<b>Item</b>	<b>Part No.</b>	<b>Qty</b>	<b>Description</b>	<b>Notes</b>
1	73119	1	Decals, safety MLT4060MVD	
2	73120	1	Decal, controls - MLT4060MVD	
3	10000009728	1	Decal, caution emergency stop	

# MAST, JUNCTION BOX AND LIGHTS TO UNIT

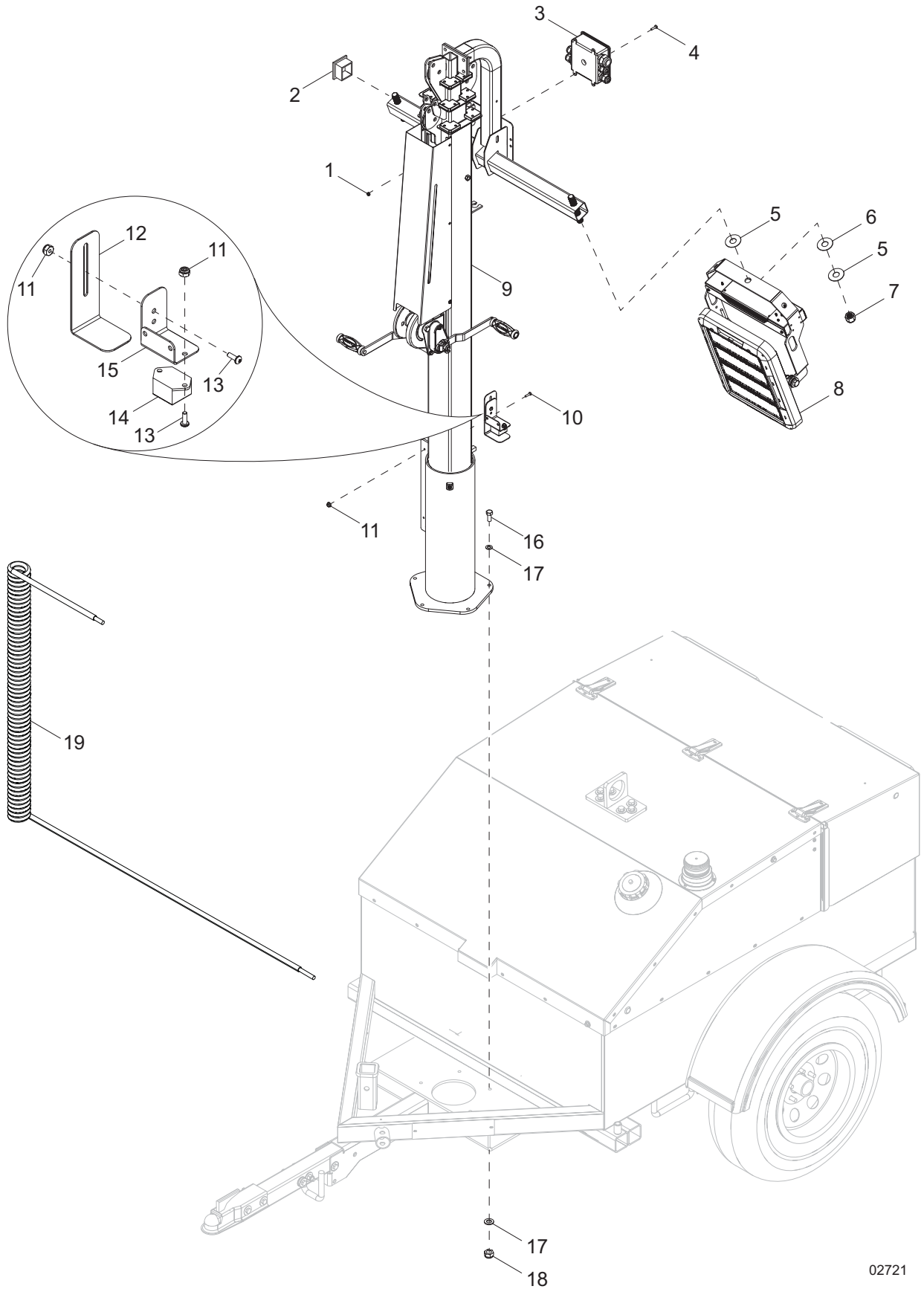

02721

## MAST, JUNCTION BOX AND LIGHTS TO UNIT

Item	Part No.	Qty	Description	Notes
1	60415	4	Nut, 10-32 nylock, SS	
2	10000023259	2	Plug, 2.0 square x .14 ga wall tube, plastic	
3	10000023328	1	Assembly, mast box	
4	60062	4	Screw, 10-32 x .750 pan Phillips, G2	
5	63357	8	Washer, .750 flat 2.0/.062 - plastic	
6	60247	4	Washer, .750 flat 2.020/.130	
7	60308	4	Nut, .750-10 nylock - SS	
8	10000019145	4	Assembly, LED light - 4 module, horizontal	
9	10000032521	1	Assembly, mast - manual winch	
10	60488	2	Screw, 8-32 x .750 pan Phillips, G2	
11	60270	6	Nut, 8-32 nylock	
12	10000008059	1	Bracket, dusk to dawn sensor	
13	62054	4	Screw, 8-32 x .500 pan Phillips - SS	
14	68763	1	Assembly, Night Watchman	
15	10000008106	1	Cover, dusk to dawn sensor	
16	60139	5	Screw, .375-16 x 1.50 hex, G5	
17	60386	10	Washer, .375 flat .993/.064	
18	60358	5	Nut, .375-16 nylock, G5	
19	10000035623	1	Coil cord w/120 inch tail	

# LIGHT ASSEMBLY

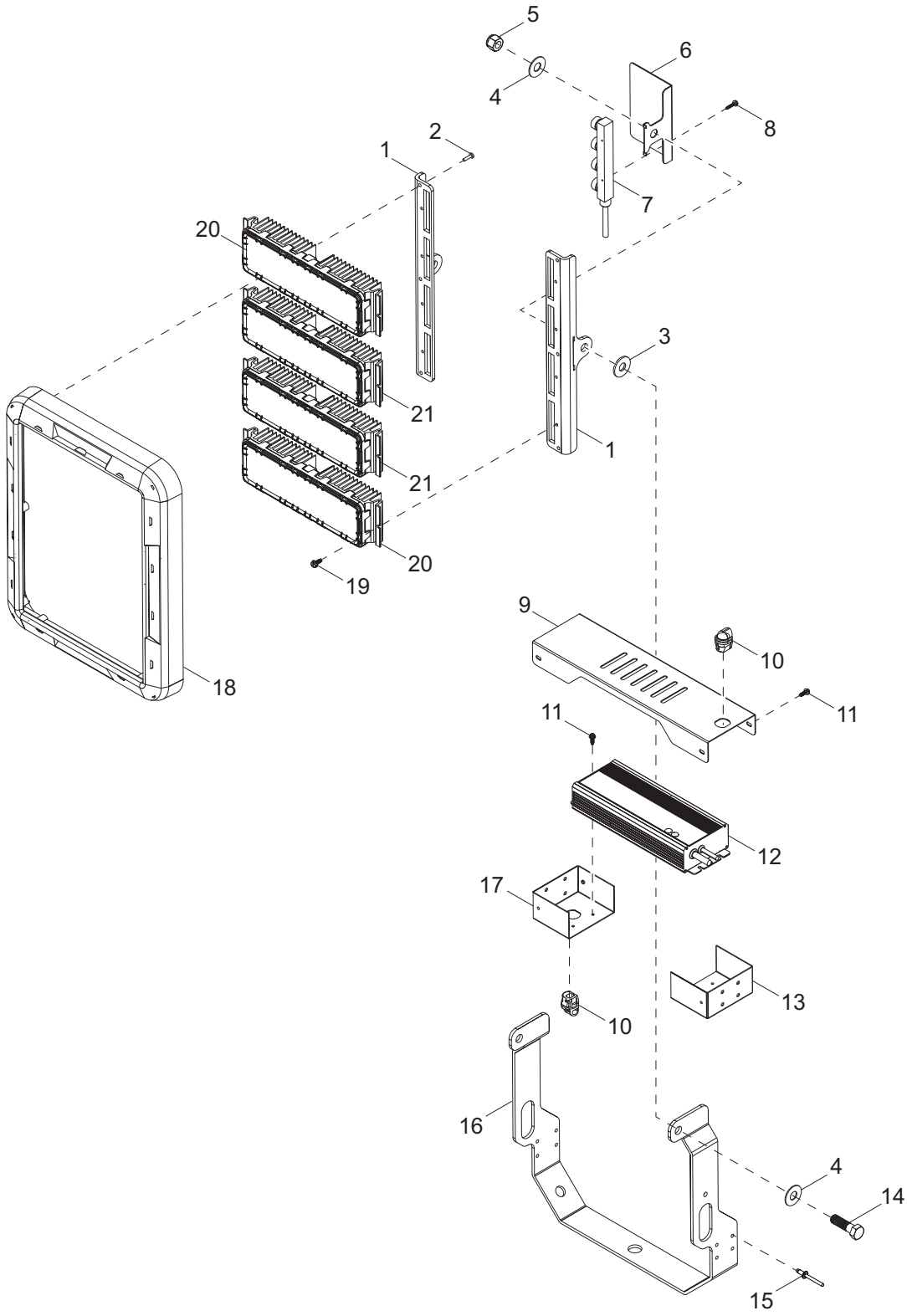

00000

## LIGHT ASSEMBLY

Item	Part No.	Qty	Description	Notes
1	10000046102	2	Frame support, LED module - horizontal	
2	10000019163	6	Screw, 8-16 x .625 PLST pan Phillips - black	
3	72134	2	Washer, .500 nylon 1.25/.100	
4	60700	4	Washer, .500 flat 1.250/.060 - SS	
5	62221	2	Nut, .500-13 nylock, G5	
6	10000019164	1	Bracket, connection block	
7	72120	1	Connector block, LED module	
8	73219	2	Screw, #6-20 x .75 sheet metal - SS	
9	10000019153	1	Enclosure, LED driver	
10	10000019152	2	Bushing, strain relief - right angle	
11	10000023706	4	Screw, 8-32 x .500 hex flanged - black	
12	72178	1	Driver, LED 30V 10.7A 321W	
13	10000023684	1	End cap 1, LED driver	
14	62249	2	Screw, .500-13 x 1.250 standard hex - SS	
15	60268	8	Rivet, .188 diameter x .126 to .250 grip	
16	10000023721	1	Trunnion, LED module - horizontal	
17	10000023663	1	End cap 2, LED driver	
18	10000019135	1	End cap, LED module	
19	10000019182	8	Screw, 10-24 x .500 hex flanged	
20	10000019170	2	Module, 60° LED 24-27VDC 60W	
21	10000019160	2	Module, 40° 28 LED 24-27VDC	
--	10000019079	4	Pigtail, 22-14GA, 3M, 314IDC	
--	10000023665	1	Cord, 18/3C, ST00W/SE00W 6.00 w/terminals	

# MAST JUNCTION BOX ASSEMBLY - HARD WIRED LIGHTS

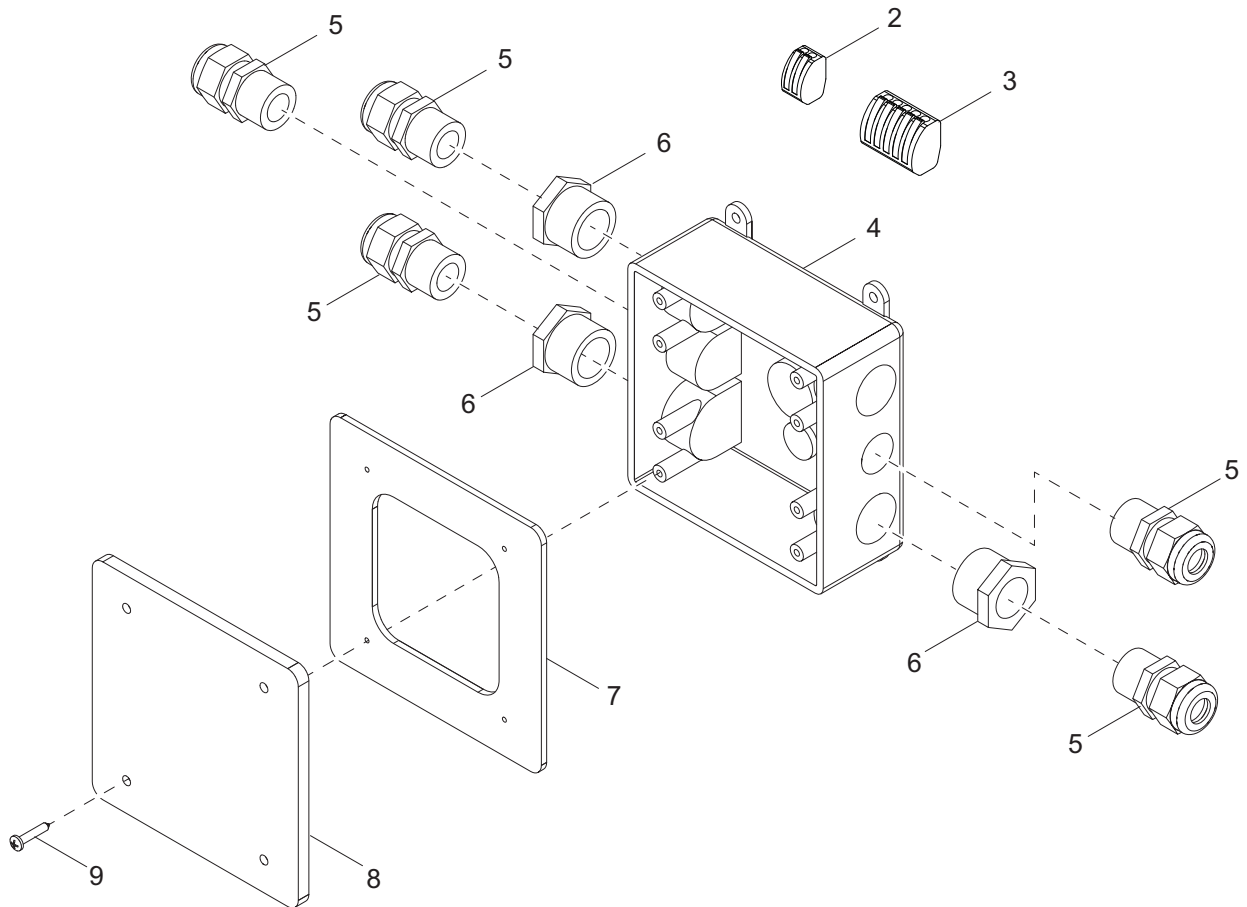
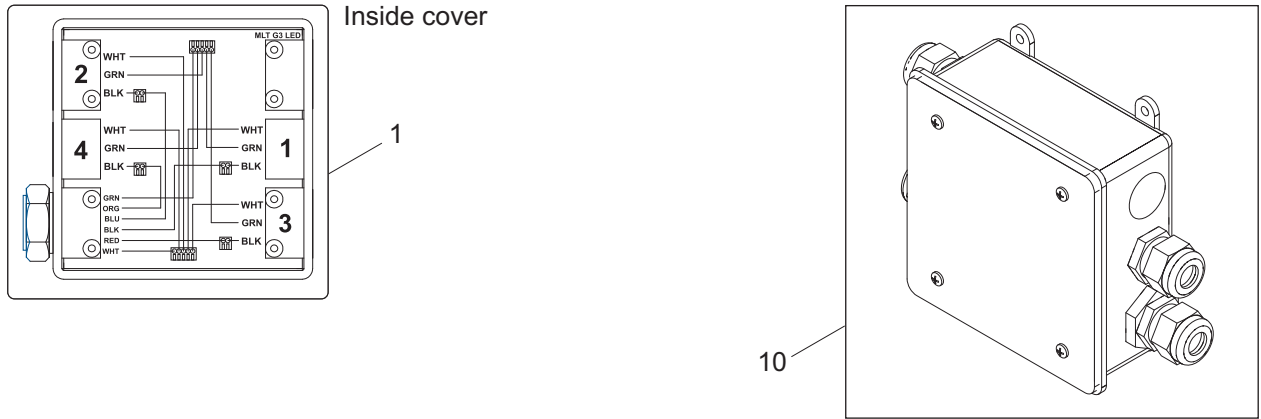

02607



## MAST JUNCTION BOX ASSEMBLY - HARD WIRED LIGHTS

Item	Part No.	Qty	Description	Notes
1	10000023482	1	Decal, mast junction box	
2	66100	4	Connector, 2 position	
3	66102	2	Connector, 5 position	
4	12094	1	Box, junction	
5	15864	5	Strain relief, .500NPT water tight	
6	60755	3	Fitting, straight .750MNPT x .500FNPT, nylon	
7	13749SRV	1	Gasket, junction box - HFI 281000	
8	12109	1	Cover, box, 2-gang plastic	
9	60424	4	Screw, 6-32 x .750 pan Phillips, G2	
10	10000023328	1	Assembly, mast junction box	

# DIFFUSED LIGHTING (IF EQUIPPED)

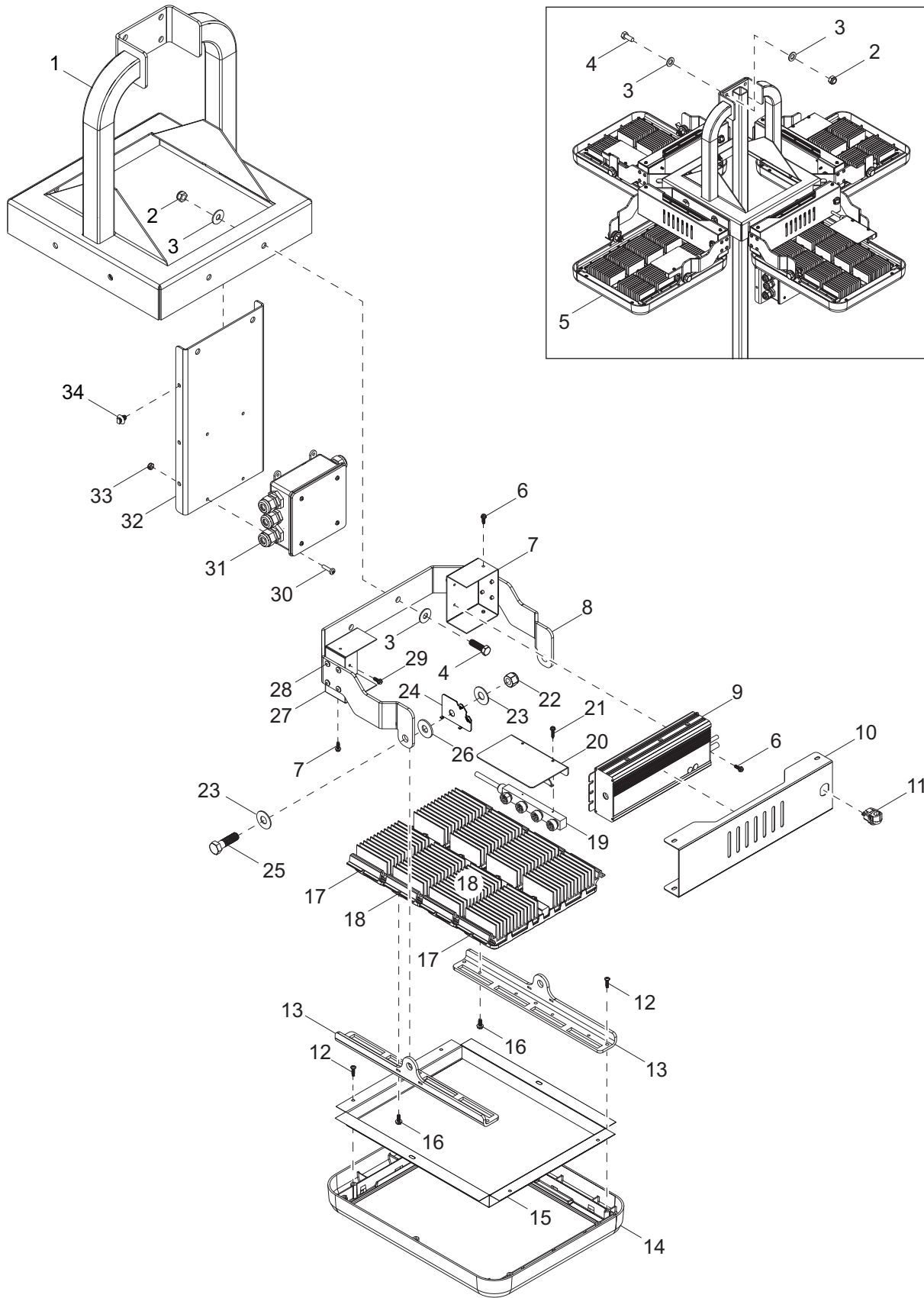

02703

## DIFFUSED LIGHTING (IF EQUIPPED)

Item	Part No.	Qty	Description	Notes
1	10000035385	1	Weldment, mount 4 - diffused	
2	60358	12	Nut, .375-16 nylock, G5	
3	60386	24	Washer, .375 flat .993/-.64	
4	60352	12	Screw, .375-16 x 1.250 hex, G5	
5	10000035376	4	Assembly, 4 LED lights - diffused	
6	10000023706	8	Screw, 8-32 x .500 flanged hex	
7	10000023684	1	End cap 1, driver - LED	
8	10000035410	1	Bracket, trunnion - 4 mod diffused	
9	10000019146	1	Driver, LED 30V, 10.7A, 321W	
10	10000019153	1	Assembly, driver enclosure - LED	
11	10000019152	2	Bushing, strain relief - right angle	
12	10000019163	4	Screw, 8-16 x 8/8 pan Phillips - black	
13	10000046102	2	Support, horizontal frame, 4 module - LED	
14	10000019135	1	Assembly, end cap, horizontal - LED	
15	10000020598	1	Lens, diffuser 90°	
16	10000019182	8	Screw, 10-24 x .500 flanged hex - black	
17	10000019170	2	Module, 60° LED 24-27VDC 60W	
18	10000019160	2	Module, 40° 28 LED 24-27VDC	
19	72120	1	Connector block, 4 module - LED	
20	10000019164	1	Bracket, conn block	
21	73219	2	Screw, #6-20 x .750 sheet metal - SS	
22	62221	2	Nut, .500-13 nylock, G5	
23	60700	4	Washer, .500 flat 1.250/.060 - SS	
24	10000044708	1	Bracket, stop 45° - 4 mod diffused	
25	62249	2	Screw, .500-13 x 1.250 standard hex - SS	
26	72134	2	Washer, .500 nylon 1.25/.100	
27	10000023663	1	End cap 2, driver - LED	
28	60268	8	Rivet, .188 diameter x .126 t0 .250 grip - SS	
29	10000019172	1	Screw, 8-32 x 3/8 flanged hex - green	
30	60062	4	Screw, 10-32 x .750 pan Phillips, G2	
31	10000034286	1	Assembly, mast box - hard wire	
32	10000035367	1	Bracket, J box mount	
33	60061	4	Nut, 10-32 nylock	
34	66685	4	Mount, cable tie .25-.28 diameter, .031-.276 grip	
--	10000019079	4	Pigtail, 22-14GA, 3M, 314IDC	
--	10000023665	1	Cord, 18/3C, STOOW/SEOOW 6.00 w/terminals	
--	34552	4	Clamp, tubing 1.00HD, .406 hole, .75WD	

# MAST ASSEMBLY

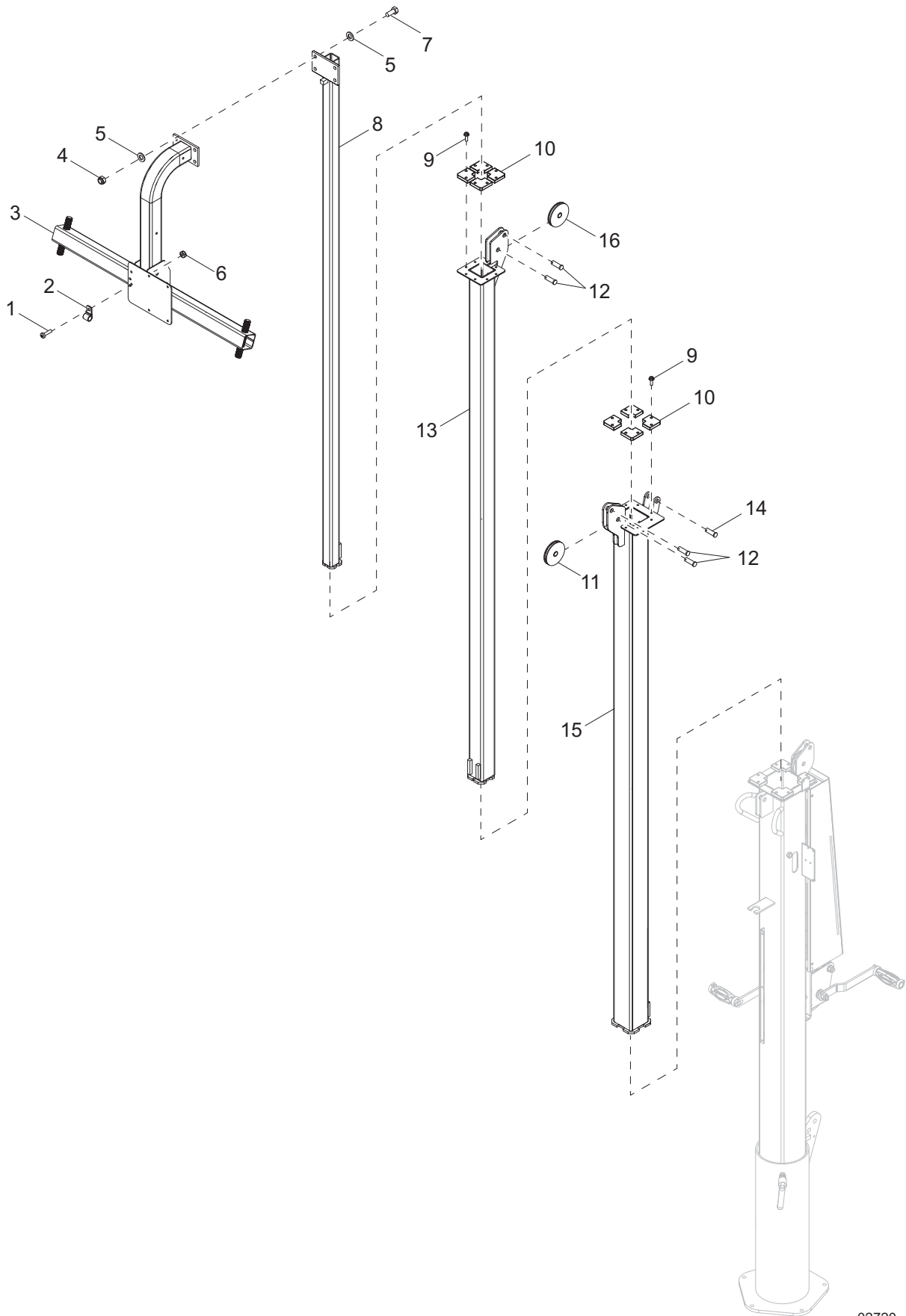

02720

## MAST ASSEMBLY

Item	Part No.	Qty	Description	Notes
1	60107	1	Screw, .250-20 x .750 serrated flange hex, G5	
2	16143	1	Clamp, tubing .500	
3	43201B	1	Weldment, mast, crossbar	
4	60358	4	Nut, .375-16 nylock, G5	
5	60386	8	Washer, .375 flat .993/.064	
6	60787	1	Nut, .250-20 nylock - SS	
7	60352	4	Screw, .375-16 x 1.250 hex, G5	
8	31264B	1	Weldment, mast - 1.50	
9	63358	16	Screw, .250-20 x .625 hex wash hd	
10	31225	8	Guide	
11	33736	1	Assembly, pulley - vertical mast	
12	63325	4	Pin, clevis .500 diameter x 1.063 UL	
13	31261B	1	Weldment, mast - 2.25	
14	35655	1	Pin, clevis .500 diameter x 1.750 ZP	
15	37465B	1	Weldment, mast - 3.0	
16	14262	1	Sheave, 3.00	
--	31247	1	Cable, .188 x 144 w/ ball swedge	winch cable
--	31248	2	Cable, .188 x 79.750 w/ball swedge	middle cable
--	31277	1	Cable, .188 x 78.0 w/ball swedge	top cable

# MAST ASSEMBLY - BOTTOM POST - MANUAL WINCH

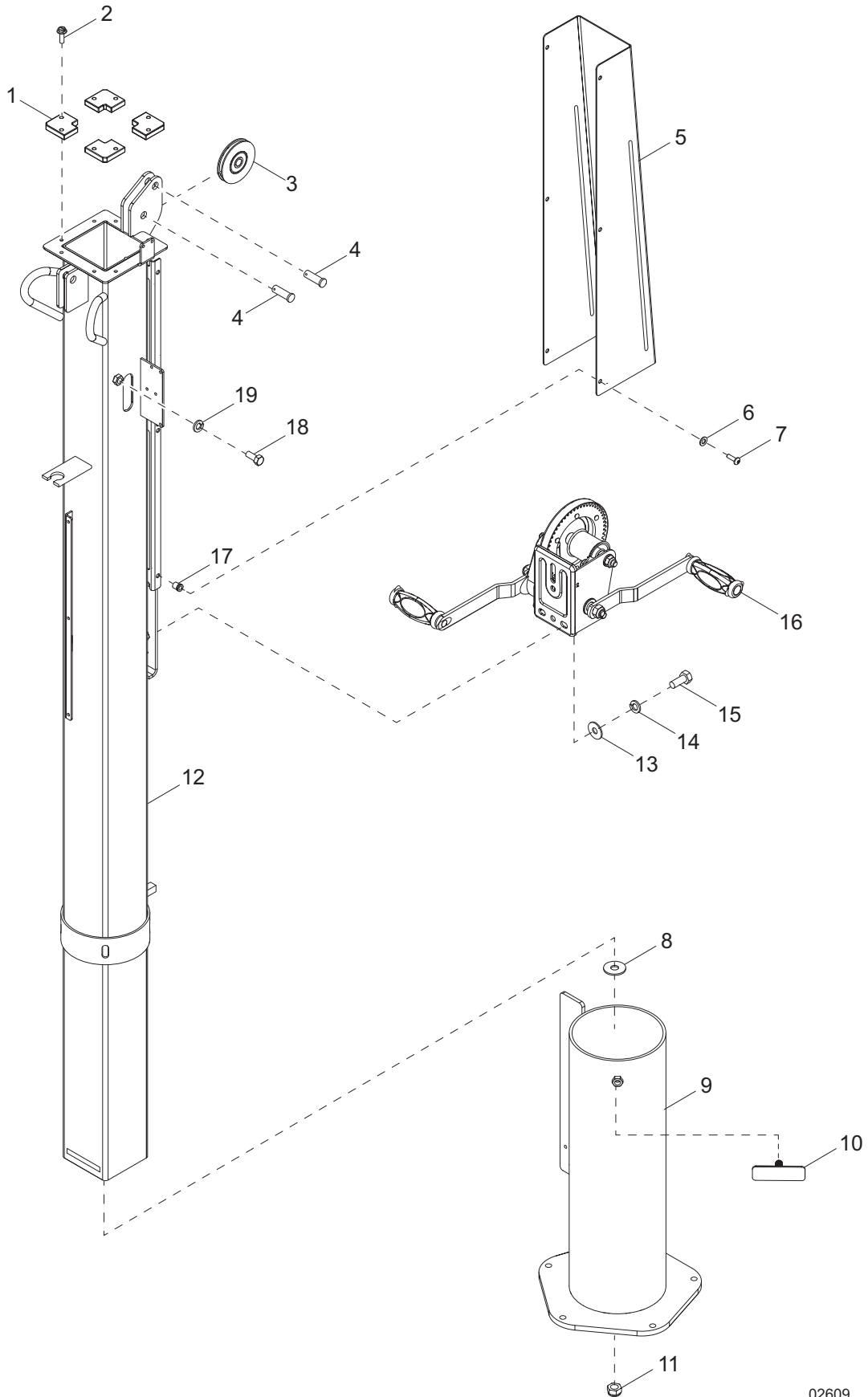

02609

## MAST ASSEMBLY - BOTTOM POST - MANUAL WINCH

Item	Part No.	Qty	Description	Notes
1	31225	4	Guide	
2	63358	8	Screw, .250-20 x .625 hex washer head	
3	33736	1	Assembly, pulley vertical mast	
4	63325	2	Pin, clevis .500 diameter x 1.063 UL	
5	72116B	1	Guard, cable	
6	60067	6	Washer, #10 flat .435/.060 - SS	
7	60398	6	Screw, 10-32 x .500 pan Phillips - SS	
8	60247	1	Washer, .750 flat 2.020/.130	
9	72032B	1	Weldment, mast rotation tube	
10	10000018317	1	Weldment, T-handle	
11	60584	1	Nut, .750-10 nylock, G5	
12	73158B	1	Weldment, mast 4.0 in	
13	60386	3	Washer, .375 flat .993/.064	
14	60206	3	Washer, .375 split lock - hardened	
15	60205	3	Screw, .375-16 x 1.0 hex, G5	
16	72127	1	Winch, manual - 1500 lb, dual handle	
17	32922	6	Insert, threaded 10-32 splined, .020-.130 grip	
18	62269	2	Screw, .375-16 x .75 hex, SS - red	
19	60703	2	Washer, .375 split lock, SS	

# MAST ASSEMBLY - BOTTOM POST - ELECTRIC WINCH

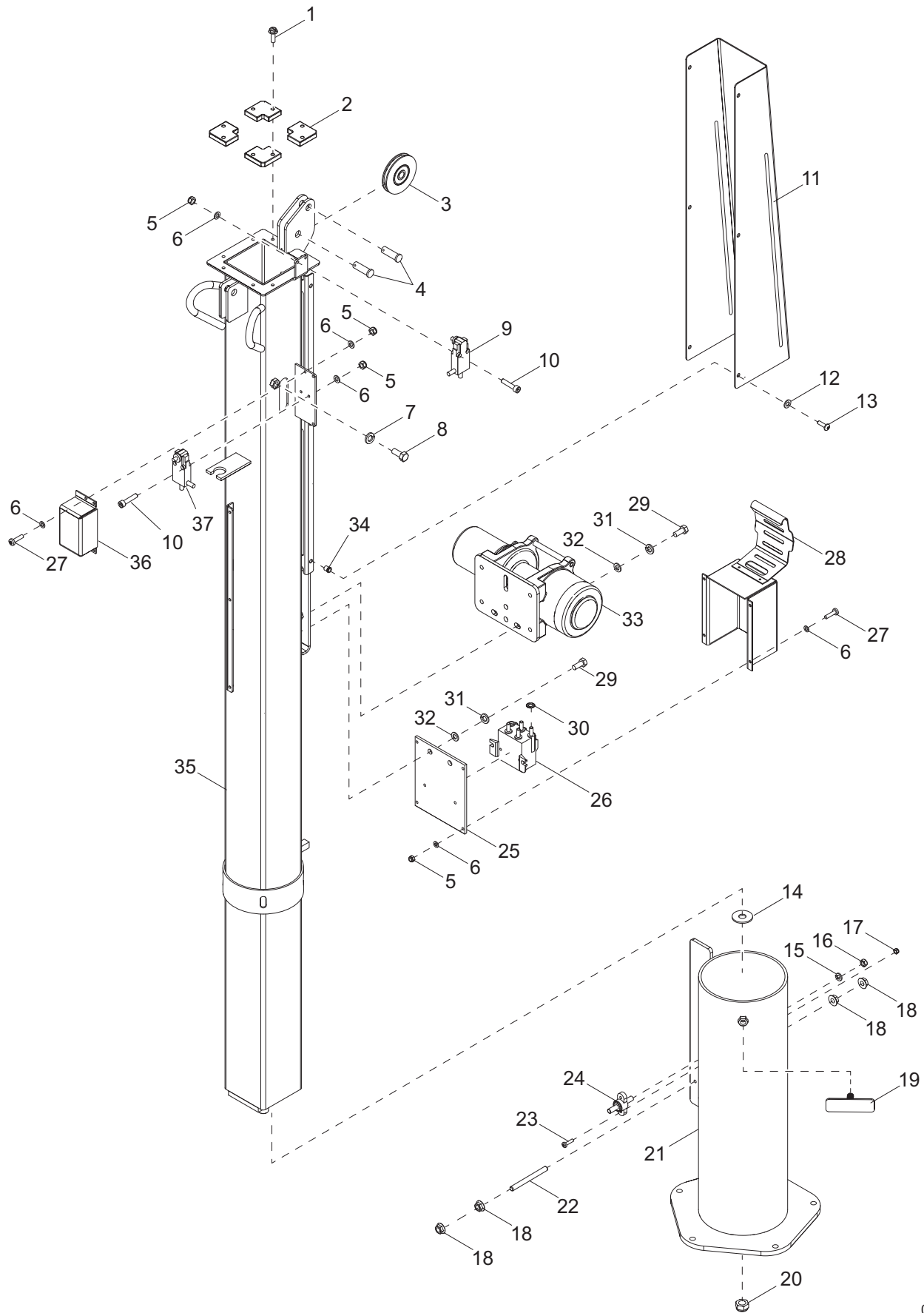

02610



## MAST ASSEMBLY - BOTTOM POST - ELECTRIC WINCH

Item	Part No.	Qty	Description	Notes
1	63358	8	Screw, .250-20 x .625 hex, washer head	
2	31225	4	Guide	
3	33736	1	Assembly, pulley vertical mast	
4	63325	2	Pin, clevis .500 diameter x 1.063 UL	
5	60207	11	Nut, 8-32 nylock, G6	
6	60269	18	Washer, #8 flat .433/.036	
7	60703	2	Washer, .375 split lock, SS	
8	62269	2	Screw, .375-16 x .75 hex, SS - red	
9	31740	1	Assembly, down switch	
10	67190	4	Screw, 8-32 x 1.125 socket head, SS	
11	72116B	1	Guard, cable	
12	60067	6	Washer, #10 flat .435/.060 - SS	
13	60398	6	Screw, 10-32 x .500 pan Phillips - SS	
14	60247	1	Washer, .750 flat 2.020/.130	
15	60206	1	Washer, .375 split lock	
16	60140	1	Nut, .375-16 hex	
17	60038	2	Nut, M5-0.80 nylock, G6	
18	60020	4	Nut, M8-1.25 serrated flange, G8.8	
19	10000018317	1	Weldment, T-handle	
20	60584	1	Nut, .750-10 nylock, G5	
21	72032B	1	Weldment, mast rotation tube	
22	18992	1	Stud, ground M8-1.25 x 100mm	
23	60037	2	Screw, M5-.80 x 20 pan Phillips, G4.8	
24	66986	1	Stud, pass-through .375-16 red	
25	37207B	1	Plate, contactor	
26	11293	1	Contactorm	Hardware included
27	60244	7	Screw, 8-32 x .750 pan Phillips, G2	
28	37468B	1	Weldment, winch cover	
29	60205	5	Screw, .375-16 x 1.0 standard hex, G5	
30	60069	4	Washer, M8 external star	
31	60206	5	Washer, .375 split lock	
32	60386	5	Washer, .375 flat .993/.064	
33	12874	1	Winch, electric - 770 lb hoist	
34	32922	6	Insert, threaded 10-32 splined, .020-.130 grip	
35	73158B	1	Weldment, mast 4.0 in	
36	37205B	1	Cover, up limit switch	
37	31739	1	Assembly, up stop switch	
--	12922	2	Boot, battery cable - red	
--	31742	1	Wire group, electric winch box	
--	31743	1	Harness, winch power cables	
--	72143	1	Harness, winch, stud-contactorm	
--	72144	1	Harness, battery to stud	

# REAR HOOD TO UNIT

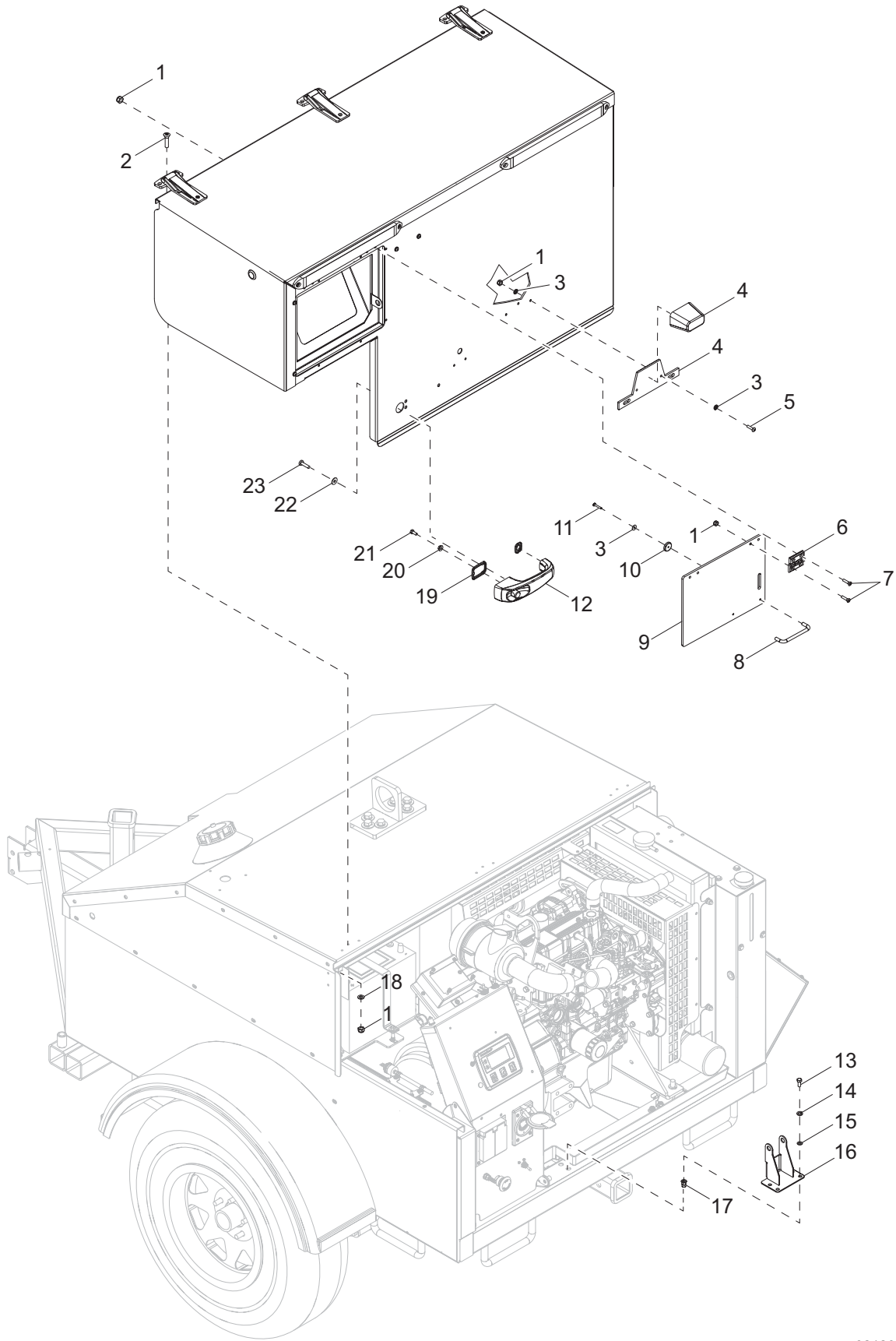

02123

## REAR HOOD TO UNIT

Item	Part No.	Qty	Description	Notes
1	60457	17	Nut, 10-24 nylock, G2	
2	35290	9	Screw, 10-24 x 1.0 flat head Phillips, SS	
3	60067	4	Washer, #10 flat .435/.060, SS	
4	10223SRV	1	Assembly, license plate light/holder	
5	60540	2	Screw, 10-24 x .750 pan Phillips, SS	
6	35394	2	Hinge, door - small	
7	73124	8	Screw, 10-24 x .875 flat head Phillips, SS	
8	37123	1	Handle, control box cover	
9	72045	1	Door, control panel	
10	29311	1	Magnet, cup 1.40 x .281 x .188 hole	
11	60695	2	Screw, 8-32 x 1.0 pan Phillips, SS	
12	35138	1	Handle, push-button	
13	60028	4	Screw, .312-18 x 1.0 hex, G5	
14	60271	4	Washer, .312 split lock	
15	60119	4	Washer, .312 flat .875.070	
16	73084B	1	Weldment, mount, door latch striker	
17	62133	4	Insert, threaded .312-18 splined, ..027-.150 grip	
18	60237	9	Washer, #10 flat .495/.036	
19	70216	1	Gasket kit, handle, push-button	
20	60036	1	Nut, M6-1.0 serrated flange, G8.8	
21	60335	1	Screw, M6-1.0 x 25 hex, SS	
22	60243	3	Washer, .250 flat .735/.060	
23	60146	3	Screw, M6-1.0 x 20 pan Phillips, G4.8	

# REAR HOOD ASSEMBLY

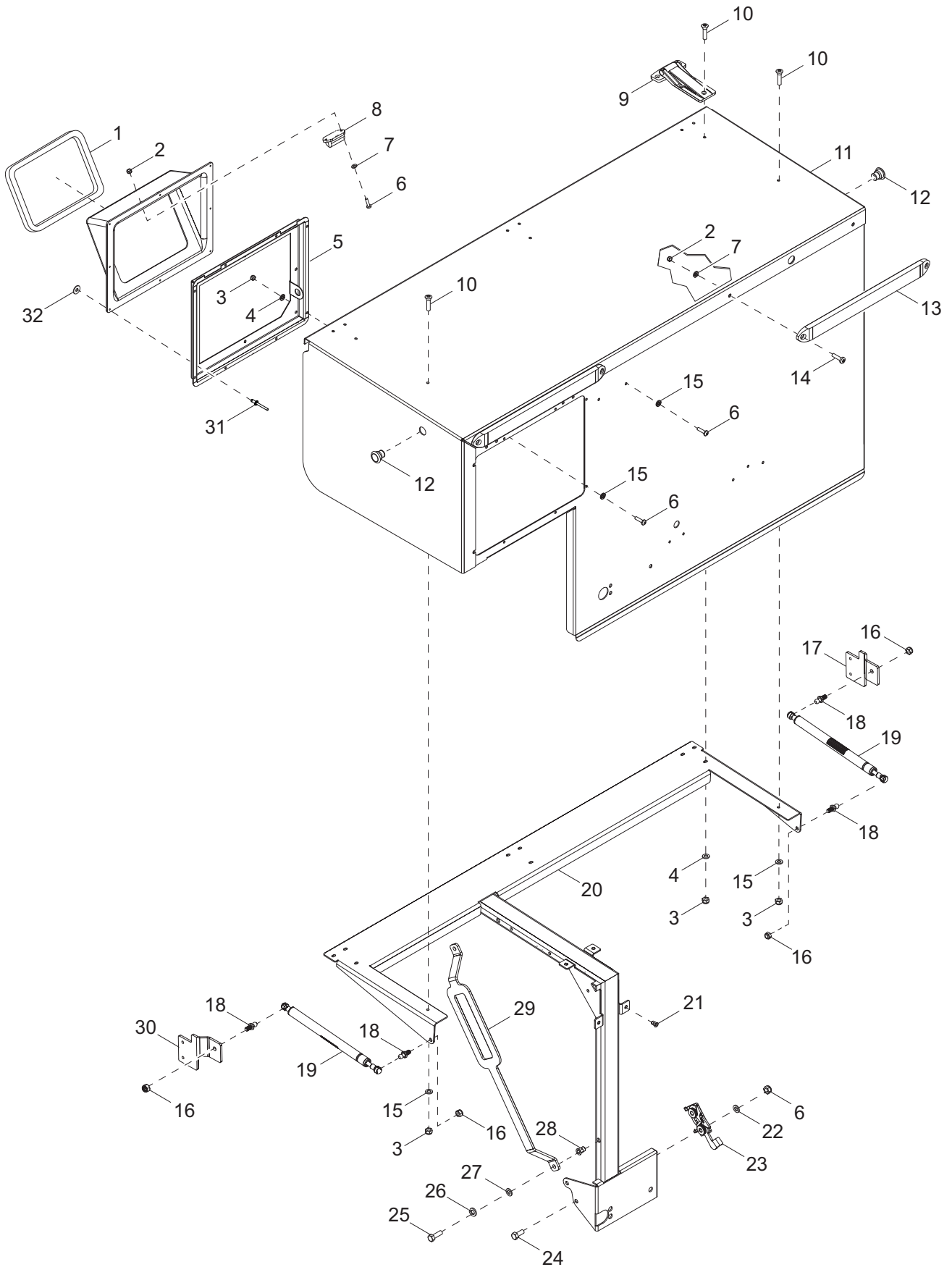

02611

## REAR HOOD ASSEMBLY

Item	Part No.	Qty	Description	Notes
1	10000018812	1	Gasket, control panel - foam	
2	60270	5	Nut, 8-32 nylock, G6	
3	60457	17	Nut, 10-24 nylock, G2	
4	60237	17	Washer, #10 flat .435/.060, SS	
5	72041B	1	Weldment, control panel base	
6	60540	20	Screw, 10-24 x .750 pan Phillips, SS	
7	60269	5	Washer, #8 flat .433/.036	
8	36963	1	Assembly, license plate light	
9	35136B	3	Hinge, flush mount	
10	35290	9	Screw, 10-24 x 1.0 flat head Phillips, SS	
11	10000032533	1	Weldment, hood assembly	
12	36962	2	Assembly, side marker light - red	
13	36960	2	Assembly, tail light	
14	60694	5	Screw, 8-32 x .750 pan Phillips, SS	
15	60067	18	Washer, #10 flat .435/.060 -SS	
16	60303	6	Nut, .312-18 nylock, G2	
17	10000026871	1	Mount, gas spring - right	
18	35293	4	Ball stud, 10MM, .312-18	
19	35137	2	Shock, gas 120 #	
20	10000030334	1	Weldment, hood support	
21	62234	2	Insert, threaded #10-32 hex, .020-.130 grip	
22	60119	4	Washer, .312 flat .875/.036	
23	35139	1	Latch, rotary	
24	62001	2	Screw, .312-18 x 1.250 hex, G5	
25	60393	2	Screw, .250-20 x 1.0 hex, G5	
26	60286	2	Washer, .250 split lock	
27	60243	2	Washer, .250 flat .735	
28	62132	1	Insert, threaded .250-20 splined .027-.165 grip	
29	73168B	1	Handle, rear hood	
30	10000026920	1	Mount, gas spring - left	
31	60268	8	Rivet, .188 diameter x .126 to .250 grip - SS	

# FRONT AND SIDE PANELS TO UNIT

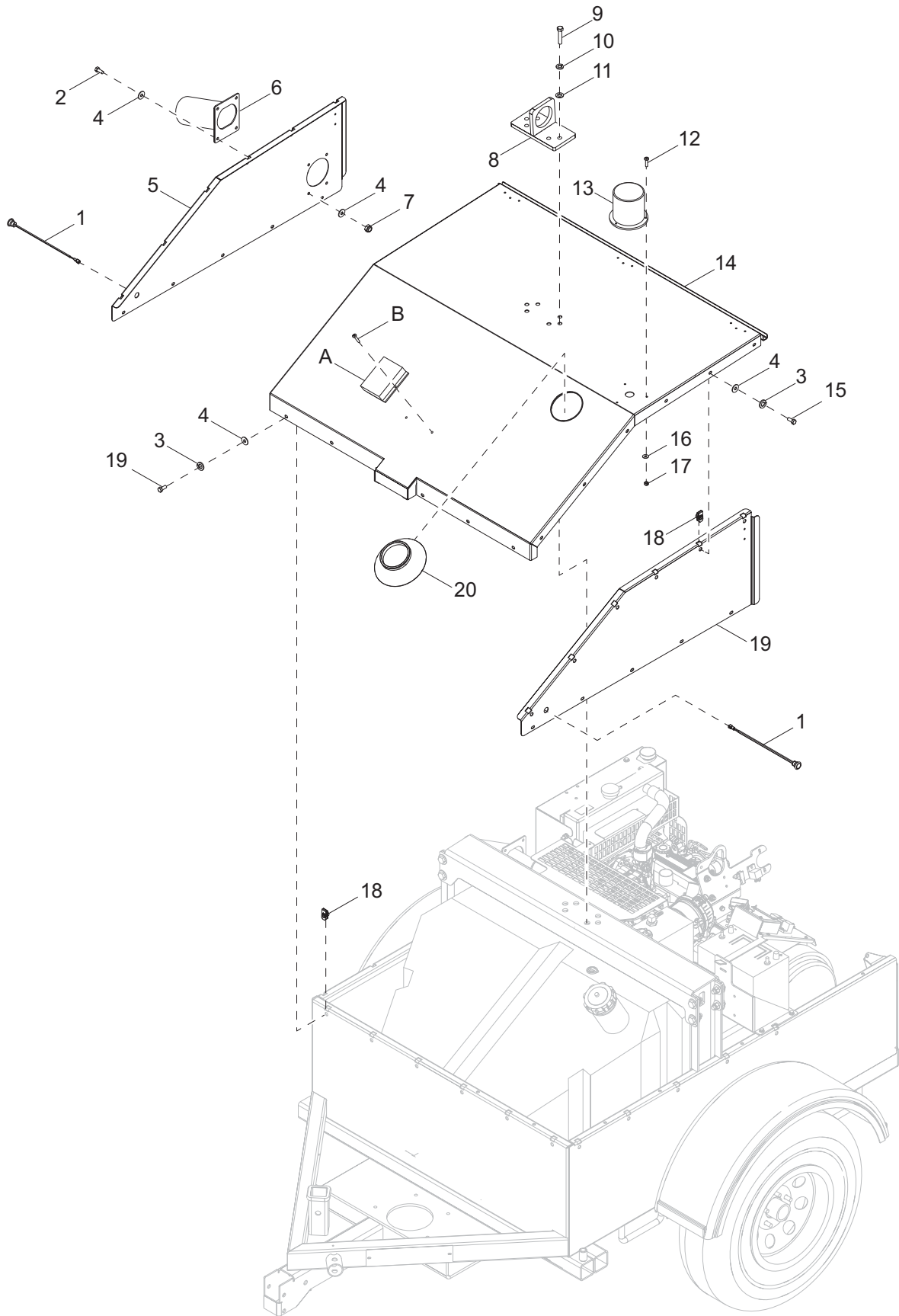

02612

## FRONT AND SIDE PANELS TO UNIT

Item	Part No.	Qty	Description	Notes
1	36961	2	Assembly, side marker light - amber	
2	60687	4	Screw, .312-18 x .750 hex, SS	
3	60701	28	Washer .312 split lock, SS	
4	60340	32	Washer, flat .875/.040, SS	
5	72015W	1	Panel, right front	
6	73114BH	1	Weldment, exhaust deflector	
7	60303	4	Nut, .312-18 nylock, G2	
8	72027B	1	Weldment, lift eye	
9	72136	6	Screw, .500-13 x 2.0 hex, G8	
10	60204	6	Washer, .500 split lock	
11	60670	6	Washer, .500 flat 1.060/.110, G8	
12	60695	3	Screw, 8-32 x 1.0 pan Phillips, SS	
13	76176	1	Light, strobe - 12V, LED - amber	
14	73118W	1	Weldment, front roof	
15	60687	28	Screw, .312-18 x .75 standard hex - SS	
16	62060	3	Washer, #8 flat .435/.060, SS	
17	60270	3	Nut, 8-32 nylock, G8	
18	62086	28	Nut, .312-18 u-clip - short type	
19	72014W	1	Panel, left front	
20	72115	1	Gasket, fuel fill	
<i>ZTR Telemetry: (if equipped)</i>				
A	37731	1	Telemetry, ZTR -MH6	
B	55075	2	Screw, .250 x 20 x .75 self-tapping	

# CONTROL BOX ASSEMBLY (1 OF 2)

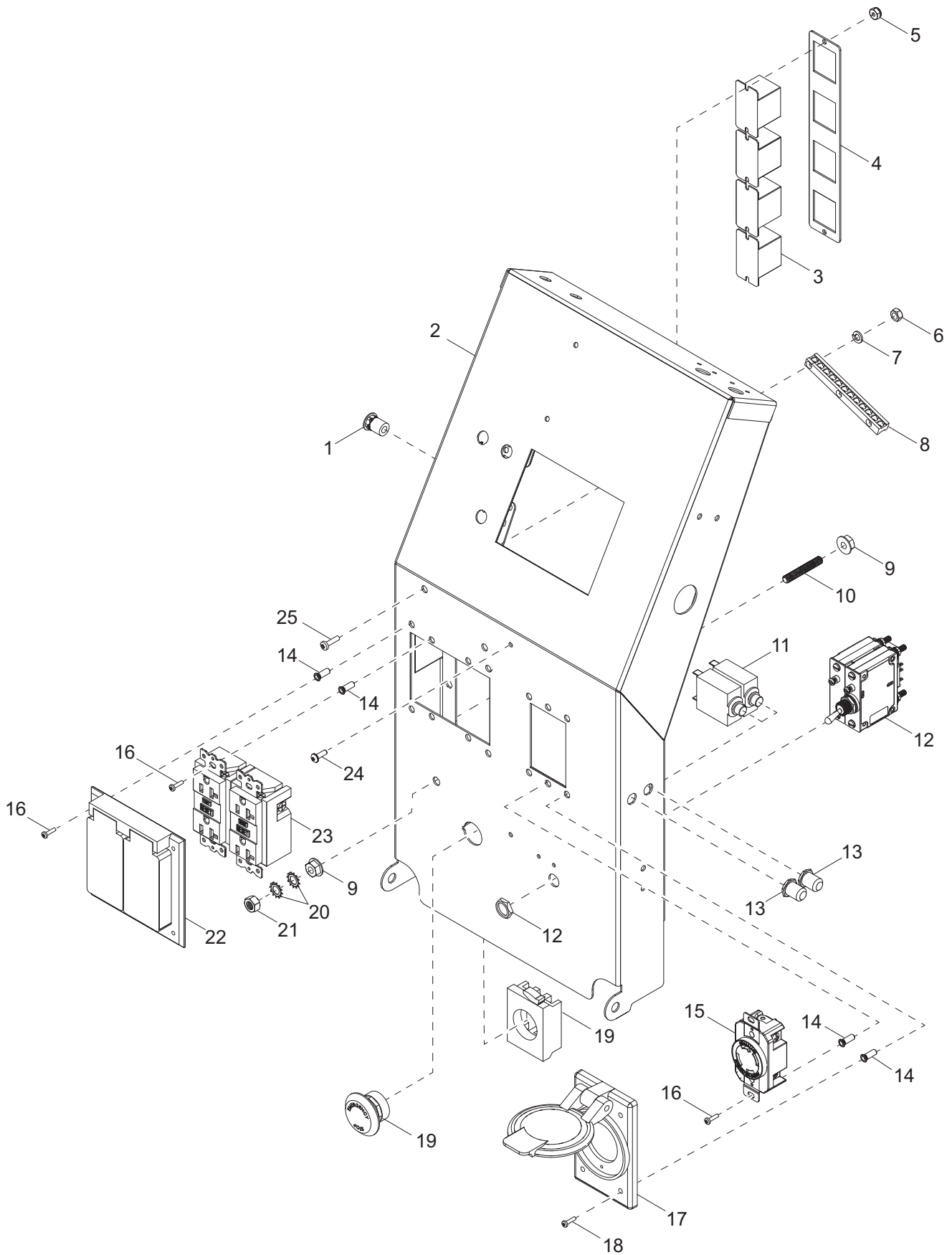

02613



## CONTROL BOX ASSEMBLY (1 OF 2)

Item	Part No.	Qty	Description	Notes
1	63097	1	Insert, threaded .313-18 hex, .027-.150 grip	
2	73160B	1	Weldment, control box	
3	29759	4	Relay, 12V coil 120-240 VAC rated	
4	38447B	1	Bracket, relay	
5	60270	2	Nut, 8-32 nylock, G6	
6	60318	2	Nut, 8-32 hex, G5	
7	60252	2	Washer, #10 split lock	
8	14204	1	Kit, ground bar	
9	62067	2	Nut, .312-18 serrated flange, SS	
10	72123	1	Stud, ground .312-18 x 2.0	
11	65849	2	Breaker, 20A, 120V - 1 pole, push-button	
12	36975	1	Breaker, 30A main	
13	36938	2	Boot, push button breaker	
14	73092	14	Insert, 8-32, .020-.080 grip	
15	65488	1	Receptacle, 240V/30A twist	
16	60526	10	Screw, 8-32 x .500 pan Phillips, G2	
17	36939	1	Cover, receptacle, 20/30A - weatherproof	
18	60244	4	Screw, 8-32 x .750 pan Phillips, G2	
19	65470	1	Switch, e-stop operator	
20	62059	2	Washer, .312 external star, SS	
21	60515	1	Nut, .312-18 hex, SS	
22	15849	1	Cover, receptacle, 20A GFC - weatherproof	
23	14130	2	Receptacle, 120V/20A GFI	
24	62054	2	Screw, 8-32 x .500 pan Phillips - SS	
25	60406	2	Screw, 8-32 x 1.00 pan Phillips, G2	

# CONTROL BOX ASSEMBLY (2 OF 2)

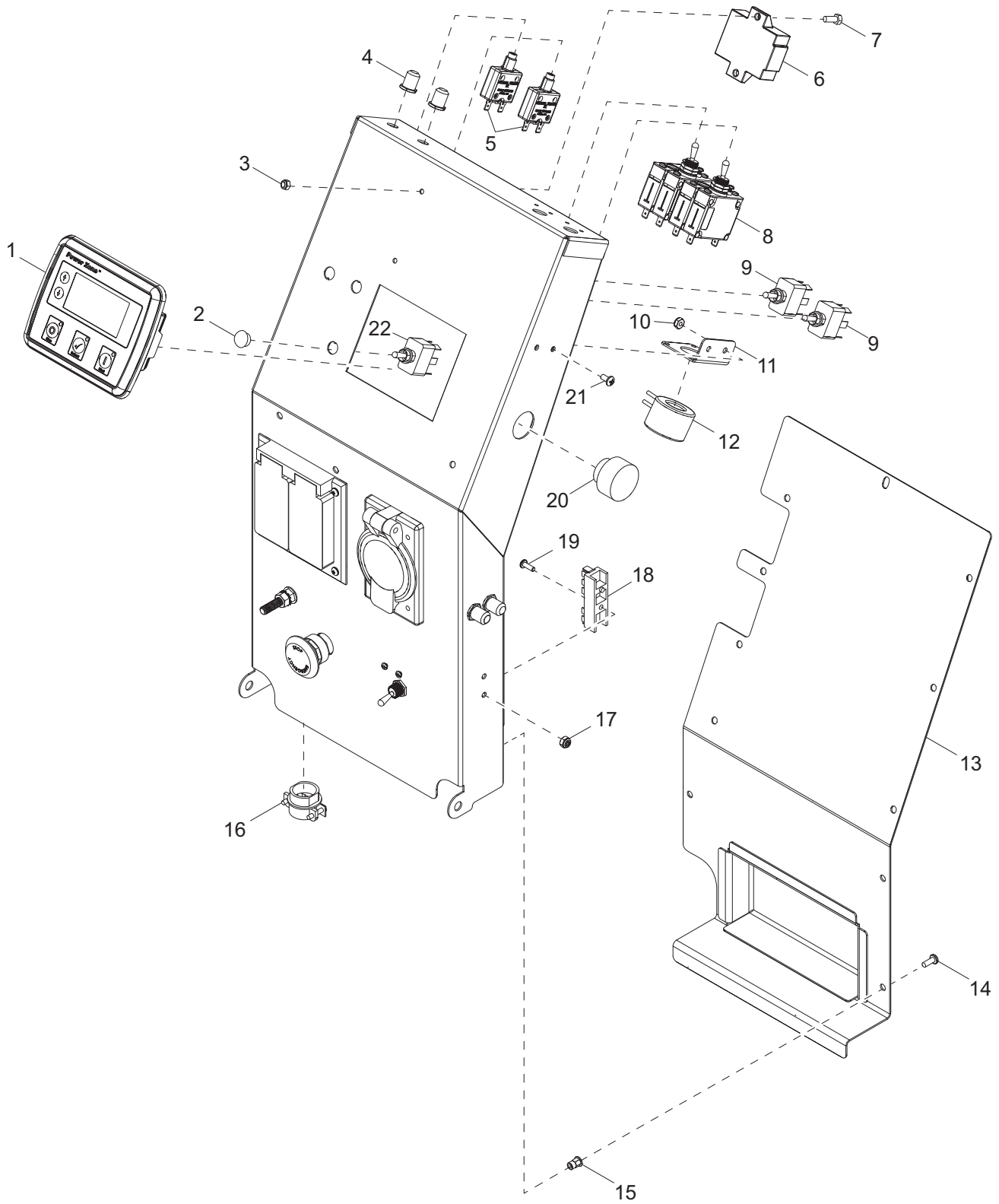

02614

## CONTROL BOX ASSEMBLY (2 OF 2)

Item	Part No.	Qty	Description	Notes
1	10000012703	1	Controller, programmed - standard	
--	10000009754	1	Controller, programmed - w/ block heater and ZTR	
--	10000011448	1	Controller, programmed - w/ block heater	
--	10000011506	1	Controller, programmed - w/ ZTR	
2	65798	1	Plug, hole .468 x .06	Manual winch only
3	60144	1	Nut, .250-20 nylock, G5	
4	36938	1	Boot, push-button breaker	
5	36937	1	Breaker, 10A DC	
6	0K2914	1	Controller, idle	
7	60281	1	Screw, .250-20 x .750 hex, G5	
8	69600	2	Breaker, 5A, 250V - 2 pole	
9	10000031493	2	Switch, toggle SPST 20A sealed	
10	60061	2	Nut, 10-32 nylock	
11	73089B	1	Bracket, CT mount	
12	66255	2	Transformer, current 100:5 wires	
13	73208B	1	Back, control box	
14	60398	11	Screw, 10-32 x .500 pan Phillips, SS	
15	62234	11	Insert, threaded 10-32 hex, .020-.130 grip	
16	14219	1	Strain relief, .750 Romex w/nut	
17	60270	1	Nut, 8-32 nylock, G6	
18	69680	1	Block, terminal, 5 and 7 position	
19	60526	1	Screw, 8-32 x .500 pan Phillips, G2	
20	73217	1	Alarm, horn - 28VDC	
21	62242	2	Screw, 10-32 x .375 pan Phillips, SS	
22	65707	1	Switch, toggle SPDT spring, weatherproof	Electric winch only
--	73120	1	Decal, control set	
--	10000032504	1	Wire group, control panel	
--	10000032505	1	Harness, control panel	
--	61025	1	Screw, .250-20 x 1.50 standard hex, SS	Use with 69656
--	60696	1	Washer, .250 flat .625/.050, SS	Use with 69656
--	60787	1	Nut, .250-20 nylock, SS	Use with 69656

# COOLING SYSTEM ASSEMBLY

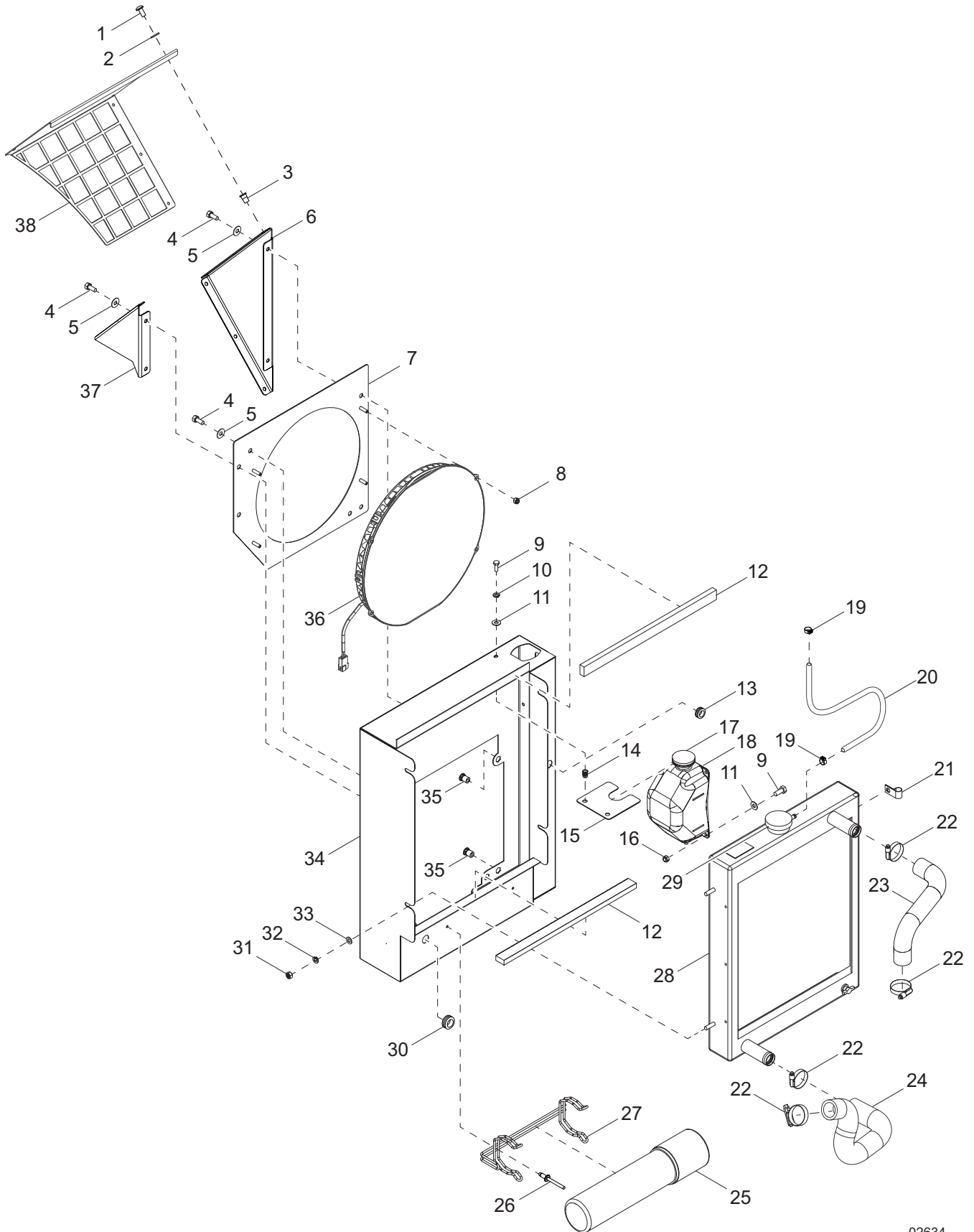

02634

## COOLING SYSTEM ASSEMBLY

Item	Part No.	Qty	Description	Notes
1	60813	8	Screw, 10-32 x 1.0 pan Phillips, SS	
2	60017	8	Washer, 10-32 flat .735/.060, SS	
3	32922	8	Insert, threaded 10-32 splined, .020-.130 grip	
4	60687	9	Screw, .312-18 x .750 hex, SS	
5	60340	9	Washer, .312 flat .875/.040, SS	
6	73192B	1	Panel, rear cover	
7	72067B	1	Assembly, fan grate	
8	60144	4	Nut, .250-20 nylock, G5	
9	60281	4	Screw, .250-20 x .750 hex, G5	
10	60286	2	Washer, .250 split lock	
11	60243	4	Washer, .250 flat .735/.060	
12	10000018806	2	Seal, fan shroud	
13	12231	1	Grommet, .500 x .250 x .750 ID hole, rubber	
14	62132	2	Insert, threaded .250-20 splined, .027-.165 grip	
15	73163B	1	Plate, coolant jug holder	
16	60161	2	Nut, .250-20 serrated flange, G5	
17	19714	1	Cap, overflow bottle	
18	72010	1	Bottle, overflow - 1.1 qt.	
19	60777	2	Clamp, hose - .312 fuel hose, crimp style	
20	50018	2.29 ft	Hose, fuel - .312 ID, 50PSI-SAE30R7	
21	60649	1	Clamp, tubing - .750 heavy-duty	
22	19338	4	Clamp, hose - SAE 016 (.68-1.50)	
23	36977SRV	1	Hose, radiator - upper	
24	16688SRV	1	Hose, radiator - lower	
25	11121	1	Holder, manual, 14.0 tube, black	
26	60195	2	Rivet, .188 x .375 to .500 grip	
27	11222	1	Bracket, manual holder	
28	13924	1	Radiator, w/fan guard	
29	19219	1	Cap, radiator	
30	12231	1	Grommet, .500ID x .250TH x .750ID hole, rubber	
31	60032	4	Nut, M8-1.25 hex, G8.8	
32	60029	4	Washer, M8 split lock	
33	60166	4	Washer, M8 flat	
34	72054B	1	Shroud, fan	
35	63097	6	Insert, threaded .312-18 hex, .027-.150 grip	
36	76187	1	Fan, 14.0 electric, 12V sucker	
37	73194B	1	Panel, front snow hood	
38	73191B	1	Panel, rear snow hood	

# ENGINE AND GENERATOR TO UNIT

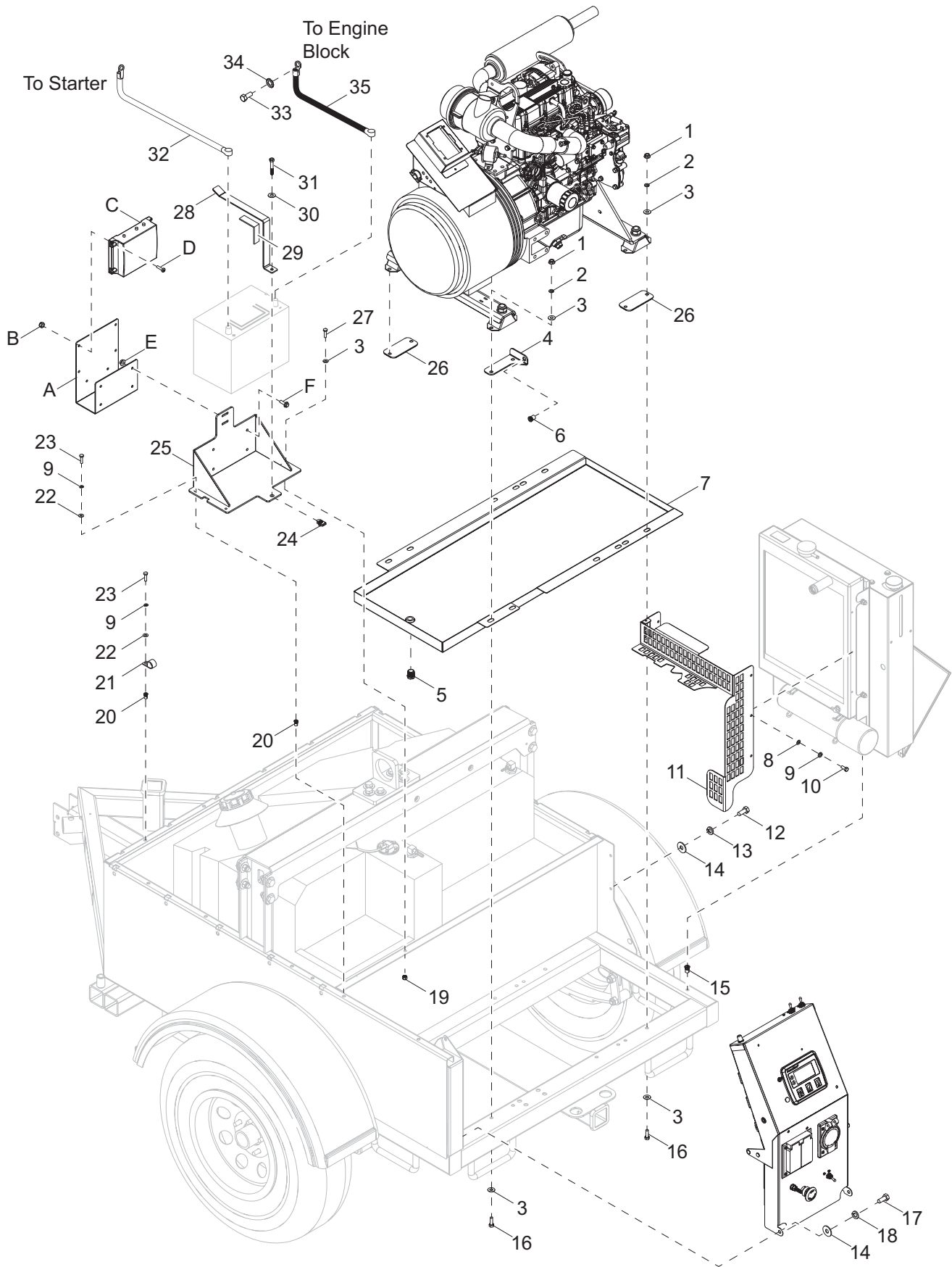

02615

## ENGINE AND GENERATOR TO UNIT

Item	Part No.	Qty	Description	Notes
1	60285	8	Nut, .312-18 hex, G2	
2	60271	8	Washer, .312 split lock	
3	60119	17	Washer, .312 flat .875/.070	
4	72078B	1	Bracket, control box mount	
5	63030	1	Fitting, plug .375 MNPT hex - brass	
6	60397	1	Insert, threaded .313-18 hex .27-.150 grip	
7	10000031859	1	Weldment, containment pan	
8	60243	4	Washer, .250 flat .735/.060	
9	60286	12	Washer, .250 split lock	
10	60281	4	Screw, .250-20 x .750 hex, G5	
11	73195B	1	Panel, belt guard	
12	60687	3	Screw, .312-18 x .750 hex, SS	
13	60271	3	Washer, .312 split lock, SS	
14	60340	6	Washer, .312 flat .875/.040, SS	
15	62133	1	Insert, threaded .312-18 splined .027-.150 grip	
16	61052	8	Screw, .312-18 x 1.50 hex, SS	
17	60507	3	Screw, .312-18 x 1.0 hex, SS	
18	60701	3	Washer, .312 split lock, SS	
19	60303	1	Nut, .312-18 nylock, G2	
20	63231	8	Insert, threaded, .250-20 hex .027-.165 grip	
21	60716	6	Clamp, tubing 1.50 - light-duty	
22	60696	8	Washer, .250 flat .625/.050, SS	
23	60393	8	Screw, .250-20 x 1.0 hex. G5	
24	62086	1	Nut, .312-18 u-clip, short type	
25	73166B	1	Tray, battery	
26	72080B	3	Spacer, generator mount	
27	60028	1	Screw, .312-18 x 1.0 hex, G5	
28	73226B	1	Bracket, battery hold down	
29	50354	1	Seal, .750 bubble type - rubber	
30	60119	1	Washer, .312 flat .875/.070	
31	60403	1	Screw, .312-18 x 2.0 standard hex, G5	
32	15074	1	Cable, battery 38.0 in, 4GA -.438 lug - red	
33	60762	1	Screw, M12-1.25 x 20 hex, G10.9	
34	60369	1	Washer, M12 external star	
35	12535	1	Cable, battery 25.0 in, 4GA -.500 lug - black	
--	69681	1	Harness, control box to generator	

**Battery Charger: (if equipped)**

A	10000011682	1	Bracket, battery charger	
B	60061	4	Nut, 10-32 nylock	
C	66212	1	Charger, battery	
D	60062	4	Screw, 10-32 x .750 pan Phillips, G2	
E	60161	4	Nut, .250-20 serrated flange, G5	
F	60528	4	Screw, .250-20 x .625 serrated flange hex, G5	

# ENGINE ASSEMBLY - RIGHT SIDE

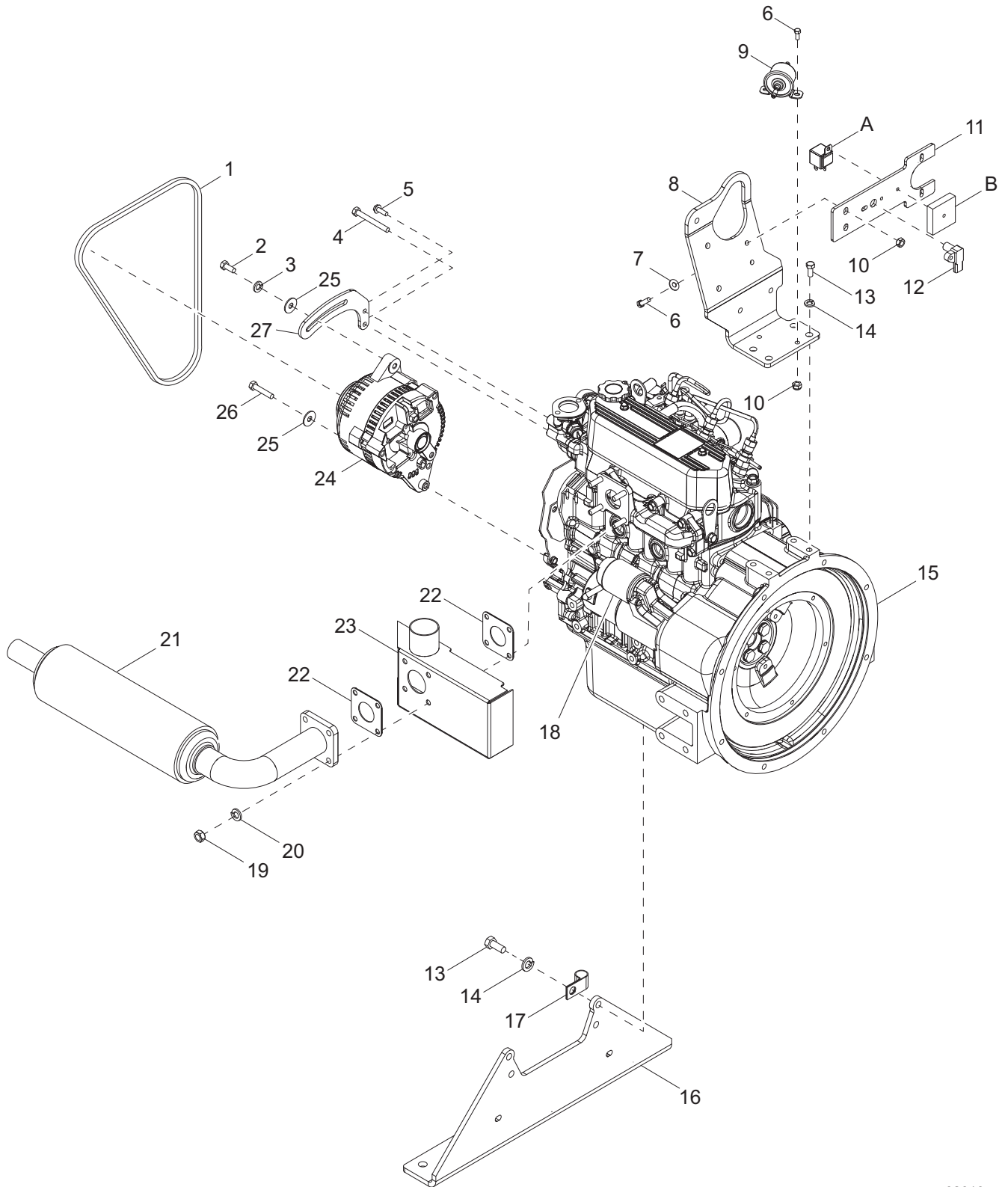

02616



## ENGINE ASSEMBLY - RIGHT SIDE

Item	Part No.	Qty	Description	Notes
1	72177	1	Belt, cold weather, L3E 36.50 in.	
2	63168	1	Screw, M8-1.25 x 30 hex	
3	60031	1	Washer, M8 flat	
4	60074	1	Screw, M8-1.25 x 65 hex, G8.8	
5	60115	1	Screw, M6 -1.00 serrated flange hex, G8.8	
6	60393	4	Screw, .250-20 x 1.0 hex, G5	
7	60243	2	Washer, .250 flat .735/.060	
8	72094B	1	Bracket, air cleaner	
9	13278SRV	1	Pump, fuel - electric	
10	60144	4	Nut, .250-20 nylock, G5	
11	72138B	1	Bracket, intake heater	
12	72175	1	Sensor, atmospheric pressure	
13	60422	8	Screw, M10-1.25 x 25 hex, G8.8	
14	60026	8	Washer, M10 split lock	
15	72155	1	Engine, Mitsubishi L3E - T4 - electric governor	
16	72053B	1	Mount, engine	
17	60649	1	Clamp, tubing .750 - heavy-duty	
18	70232	1	Starter	
19	60032	4	Nut, M8-1.25 x hex, G8.8	
20	60271	4	Washer, .312 split lock	
21	73113	1	Muffler	
22	11042SRV	2	Gasket, muffler	
23	73169BH	1	Weldment, exhaust heat shield	
24	72129	1	Alternator, 12V, 60A	
25	60019	1	Washer, .312 flat .875/.070	
26	60782	1	Screw, .312-18 x 2.50 hex, SS	
27	73193B	1	Bracket, alternator	

*Positive Air Shutdown: (if equipped)*

A	66455	1	Relay, 12V, 70A N.C./80A N.O. w/diode
B	68528	1	Relay, SPDT 10A 12VDC - time delay - 1 sec
--	60414	2	Screw, .250-20 x 1.50 standard hex, G5
--	60144	2	Nut, .250-20 nylock, G5
--	60286	2	Washer, .250 split lock
--	60243	2	Washer, .250 flat .735/.060
--	50051	1.30 ft	Hose, fuel .375 ID 50PSI SAE 30R7
--	50051	.125 ft	Hose, fuel .375 ID 50PSI SAE 30R7
--	63063	4	Clamp, hose .328 to .390 crimp style
--	40734	1	Fitting, strt .250MNPT x .375 barb - brass
--	1000009169	1	Plug, .375 barb - brass

**Note:** Engine parts used in all Generac Mobile Products, LLC equipment carry the Original Equipment Manufacturer (OEM) warranty unless otherwise stated. OEM warranty parts must be purchased through an OEM dealer. Please contact Generac Mobile Products, LLC with questions.

# ENGINE ASSEMBLY - LEFT SIDE

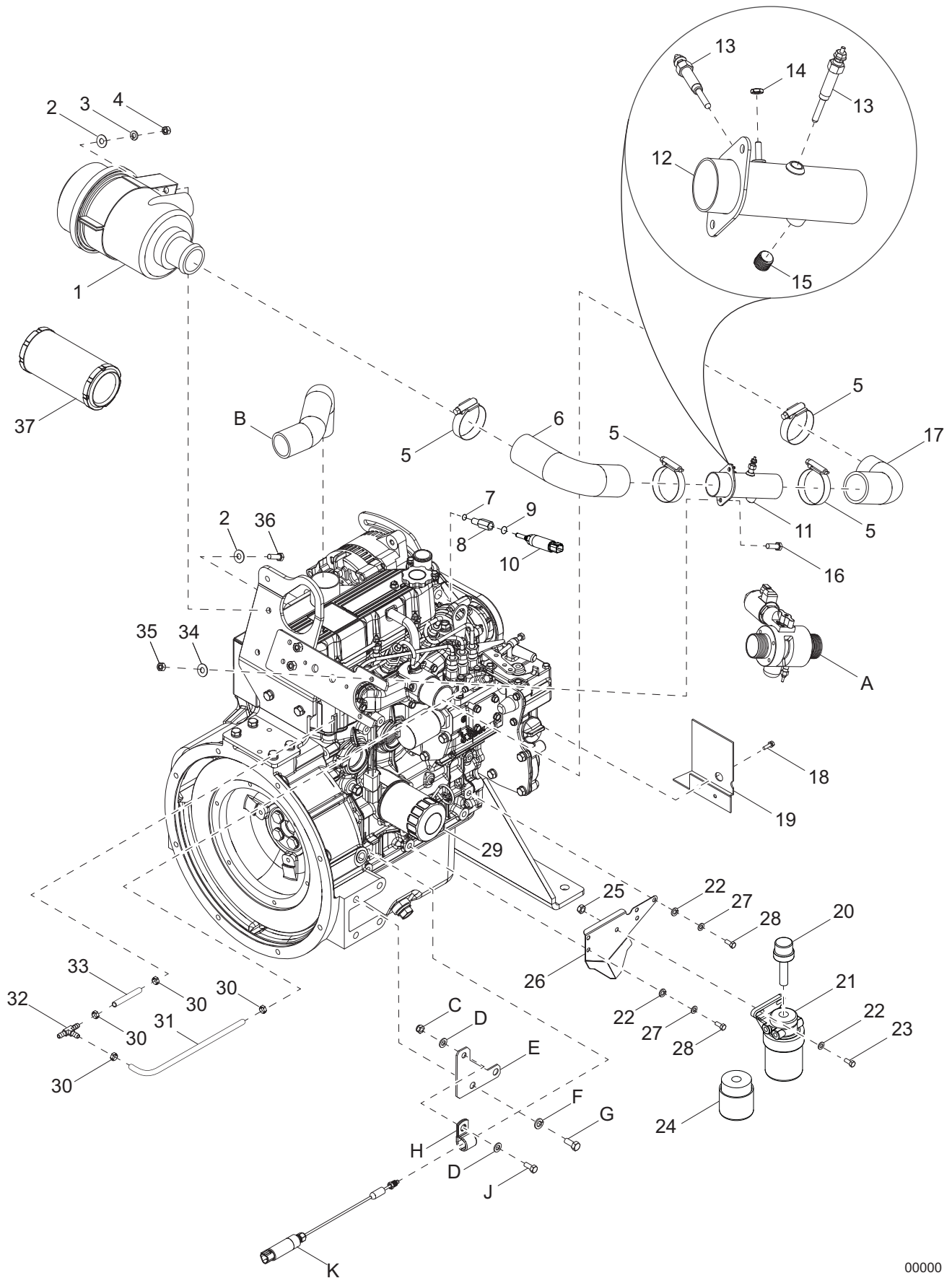

00000

## ENGINE ASSEMBLY - LEFT SIDE

Item	Part No.	Qty	Description	Notes
1	10000021718	1	Filter, air with bracket	
2	60119	4	Washer, .312 flat .875/.070	
3	60271	2	Washer, .312 split lock	
4	60285	2	Nut, .312--18 hex, G2	
5	60316	4	Clamp, hose - SAE 032 (1.56-2.50)	
6	70100	1	Hose, intake, air filter to heater	
7	69959	1	Washer, 16mm - sealing	
8	73213	1	Fitting, adapter M16-1.5 to .437-15 UNC	
9	56493	1	Washer, pressure - sealing	
10	10000008988	1	Switch, NC, intake heater	
11	10000036462	1	Assembly, intake heater	
12	72141BH	1	Weldment, intake heater	
13	16693SRV	2	Glow plug	
14	14231	1	Nut, 10-32 hex, G2	
15	52646	1	Fitting, plug .250NPT x flush mount	
16	60518	2	Screw, .250-20 x 1.50 standard hex, G5	
17	70101	1	Hose, intake, air filter-heater-engine	
18	10184	2	Screw, w/washer	
19	11691	1	Bracket, guard - lower radiator hose	
20	13876	1	Heater, fuel filter	
21	10000022110	1	Filter, fuel - head and element	Incl 10000023037
22	60027	5	Washer, M10 flat	
23	60352	2	Screw, .375-16 x 1.1250 standard hex, G5	
24	10000023037	1	Filter, fuel - element	
25	60358	2	Nut, .375-16 hex, G5	
26	72060B	1	Plate, oil deflector	
27	60026	3	Washer, M10 split lock	
28	60422	3	Screw, M10-1.125 x 25 standard hex, G8.8	
29	70124	1	Filter, oil	
30	60778	4	Clamp, hose, .188, crimp style	
31	14211	1.0 ft	Hose, fuel .188ID, 50 PSI, SAE 30R7	
32	17145	1	Fitting, tee .188 x .188 x .188 barb	
33	14211	.33.0 ft	Hose, fuel .188ID, 50 PSI, SAE 30R7	
34	60696	2	Washer, .250 flat .625/.050, SS	
35	60144	2	Nut, .250-10 nylock, G5	
36	60028	2	Screw, .312-18 x 1.0 hex, G5	
37	16444	1	Element, air filter	

*Positive Air Shutdown: (if equipped)*

A 72137 1 Intake heater w.PAS

*Intake Hose: (if equipped)*

B 72131 1 Hose, air intake

*Keep Run Switch: (if equipped)*

C 60303 1 Nut, .312-18 nylock, G2  
D 60119 2 Washer, .312 flat .875/.070  
E 10000034877 1 Bracket, mounting  
F 60011 2 Washer, M12 split lock  
G 61087 2 Screw, M12-1.25 x 25 standard hex, G10.9  
H 34552 1 Clamp, tubing 1.00 - HD  
J 60726 1 Screw, .312-18 x 1.00 standard hex, G5  
K 10000012620 1 Switch, fixed temperature - ambient air  
-- A0000046925 1 Harness, KRS extension

# GENERATOR ASSEMBLY

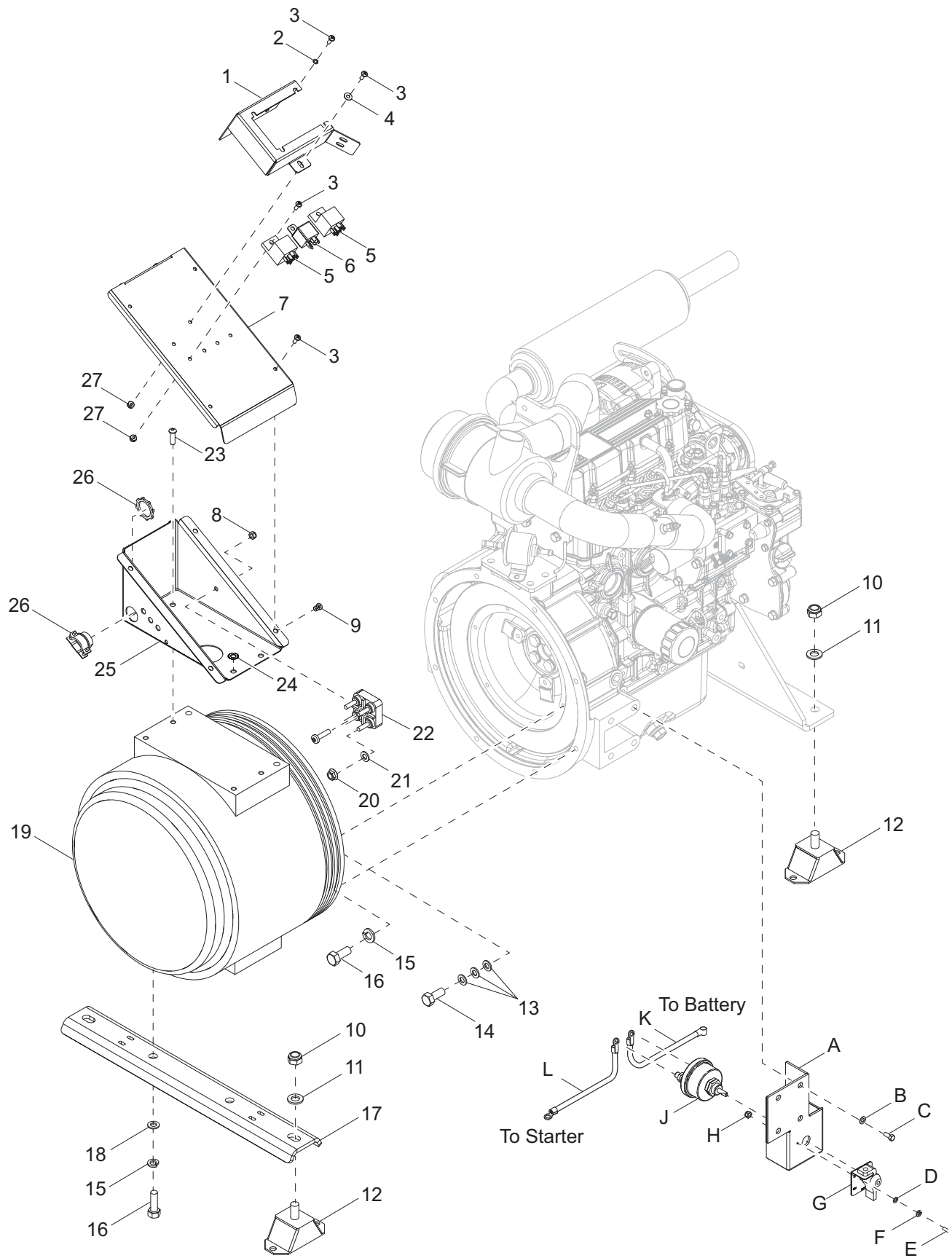

02125

## GENERATOR ASSEMBLY

Item	Part No.	Qty	Description	Notes
1	69956B	1	Cover, Bussman box	
2	60252	4	Washer, #10 split lock	
3	60398	14	Screw, 10-32 x .500 pan Phillips - thread forming, G2	
4	60237	3	Washer, #10 flat .495/.036	
5	66455	2	Relay, 12V 70A N.C./80A N.O. w/diode	
6	65049	1	Relay, 12V 30/40 N.O. w/diode	
7	76914B	1	Cover, generator box	
8	60457	1	Nut, 10-24 nylock, G2	
9	62234	4	Insert, threaded #10-32 hex .020-.130 grip	
10	60784	4	Nut, .312-18 nylock	
11	60309	2	Washer, .500 flat 1.060/.090	
12	17948	4	Isolator, 150 lbs - rubber	
13	60166	18	Washer, M8 flat	
14	60165	6	Screw, M8-1.25 x 16 hex, G10.9	
15	60026	10	Washer, M10 split lock	
16	60494	10	Screw, M10-1.25 x 30 hex, G8.8	
17	72048B	1	Mounting rail, generator	
18	60027	2	Washer, M10 flat	
19	13740	1	Generator, Marathon 331CSA/B3018, 8Kw	
20	60036	4	Nut, M6-1.0 serrated flange, G8.8	
21	60067	4	Washer, #10 flat .435/.060, SS	
22	65519	1	Block, terminal	
23	72162	4	Screw, 10-24 x .750 pan Phillips, SS	
24	60053	4	Washer, .375 external star	
25	72057B	1	Box, generator base	
26	14219	1	Strain relief, .750 Romex w/nut	
27	60061	7	Nut, #10-32 nylock	
--	69752	1	Harness, main	
--	60744	1	Washer, .750 flat 1.250/.060	Use with 69752
--	61082	1	Screw, M8-1.25 x 20 hex, G8.8	Use with 69752

*Battery Disconnect: (if equipped)*

A	10000008538	1	Bracket, battery disconnect
B	60026	4	Washer, M10 split lock
C	60422	4	Screw, M8-1.25 x 25 carriage square, SS
D	60237	2	Washer, #10 flat .495/.036
E	60252	2	Washer, #10 split lock
F	60277	2	Screw, 10-32 x .500 pan Phillips, G2
G	65499	1	Lockout, switch
H	60061	2	Nut, 10-32 nylock
J	65498	1	Switch, disconnect
K	10000008986	1	Cable, battery 50.0 in 4GA, w/boot - red
L	10000009040	1	Cable, battery 50.0 in 4 GA .375 ring - red

# BLOCK HEATER (IF EQUIPPED)

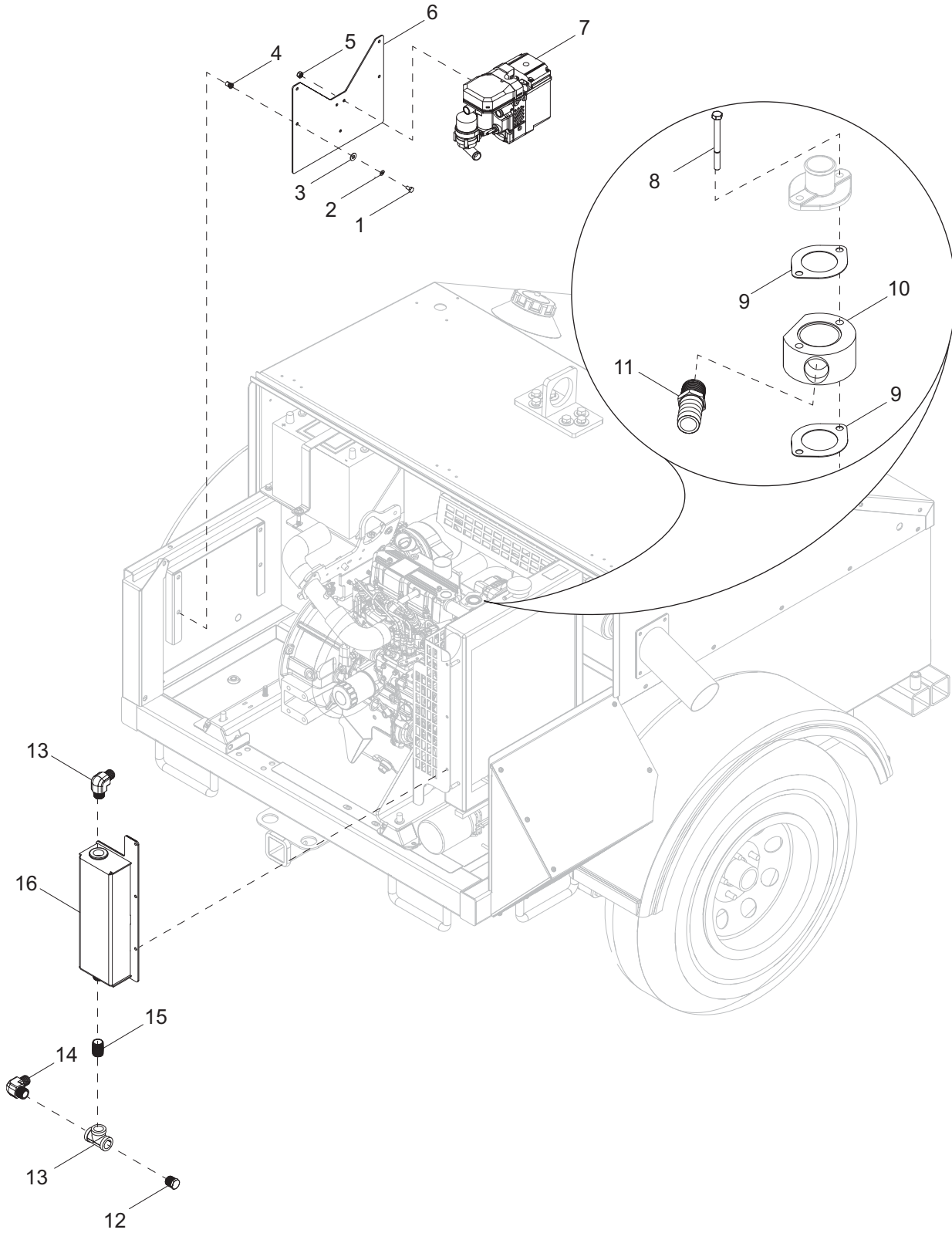

02617

## BLOCK HEATER (IF EQUIPPED)

Item	Part No.	Qty	Description	Notes
1	60647	4	Screw, .250-20 x .500 standard hex, G5	
2	60286	4	Washer, .250 split lock	
3	60243	4	Washer, .250 flat .735/.060- SS	
4	63231	4	Insert, threaded .250-20 hex .027-.165 grip	
5	60047	3	Nut, M6-1.00 nylock, G8.8	
6	10000022656	1	Bracket, block heater	
7	10000036017	1	Heater, coolant with harness	
8	60368	2	Screw, M6-1.00 x 50 standard hex - SS	
9	12214	2	Gasket, thermostat	
10	10000030642	1	Housing, thermostat DFBH	
11	60437	1	Fitting, straight .500NPT x .750 barb	
12	63031	1	Fitting, plug.750MNPT hex - brass	
13	61044	1	Fitting, tee .750NPT - brass	
14	27673	2	Fitting, 90° - .750MNPT x .750 barb - brass	
15	62027	1	Fitting, nipple .750NPT x close - brass	
16	10000031268	1	Weldment, coolant reservoir	
--	60365	5	Clamp, hose SAE 010 (.56-1.06)	
--	10000032248	8.5 ft	Hose, coolant .750 ID 20R3	
--	10000036461	1	Assembly, block heater	

**Note:** Engine parts used in all Generac Mobile Products, LLC equipment carry the Original Equipment Manufacturer (OEM) warranty unless otherwise stated. OEM warranty parts must be purchased through an OEM dealer. Please contact Generac Mobile Products, LLC with questions.

# FUEL TANK TO UNIT

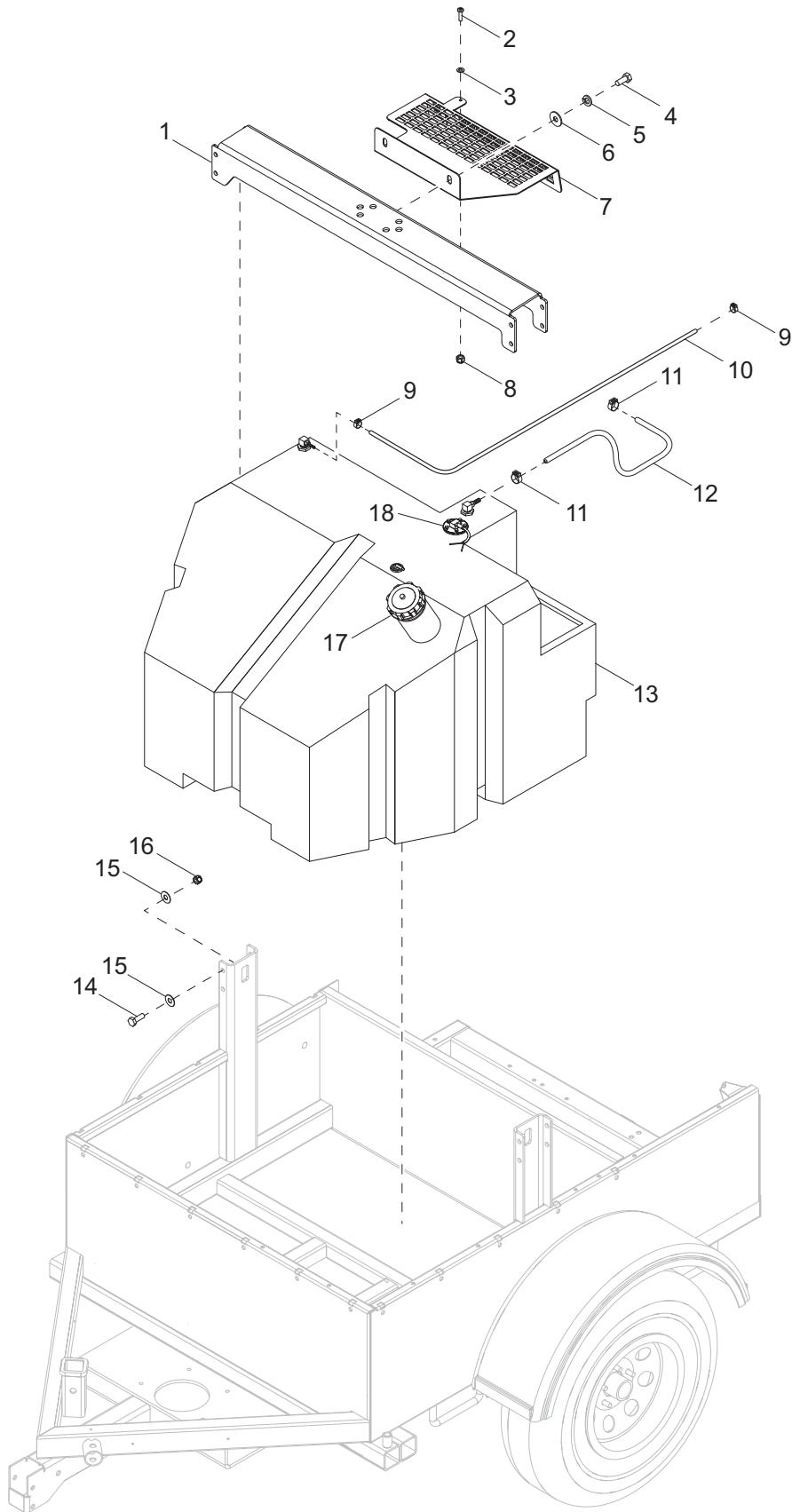

02618



## FUEL TANK TO UNIT

Item	Part No.	Qty	Description	Notes
1	73088B	1	Weldment, lift structure	
2	60687	1	Screw, .312-18 x .750 standard hex	
3	60067	1	Washer, #10 flat .435/.060 - SS	
4	60388	2	Screw, .500-13 x 1.50 hex, G5	
5	60276	2	Washer, .500 split lock	
6	60309	2	Washer, .500 flat 1.060/.090	
7	72172B	1	Guard, exhaust	
8	60061	1	Nut, 10-32 nylock	
9	60778	2	Clamp, hose, .188, crimp-style	
10	14211	3.667 ft	Hose, fuel - .188ID, 50PSI, SAE 30R7	
11	60777	2	Clamp, hose, .312, crimp-style	
12	50018	1.5 ft	Hose, fuel - .312ID, 50PSI, SAE 30R7	
13	72016	1	Tank, fuel - 104 gallon	
14	61101	8	Screw, .500-13 x 1.0 hex, G8	
15	60670	16	Washer, .500 flat 1.060/.110, G8	
16	60668	8	Nut, .500-13 nylock, G8	
17	16326	1	Cap, fuel tank 3.50 diameter	
18	10000035844	1	Sender, fuel 24.00	

# TRAILER ASSEMBLY

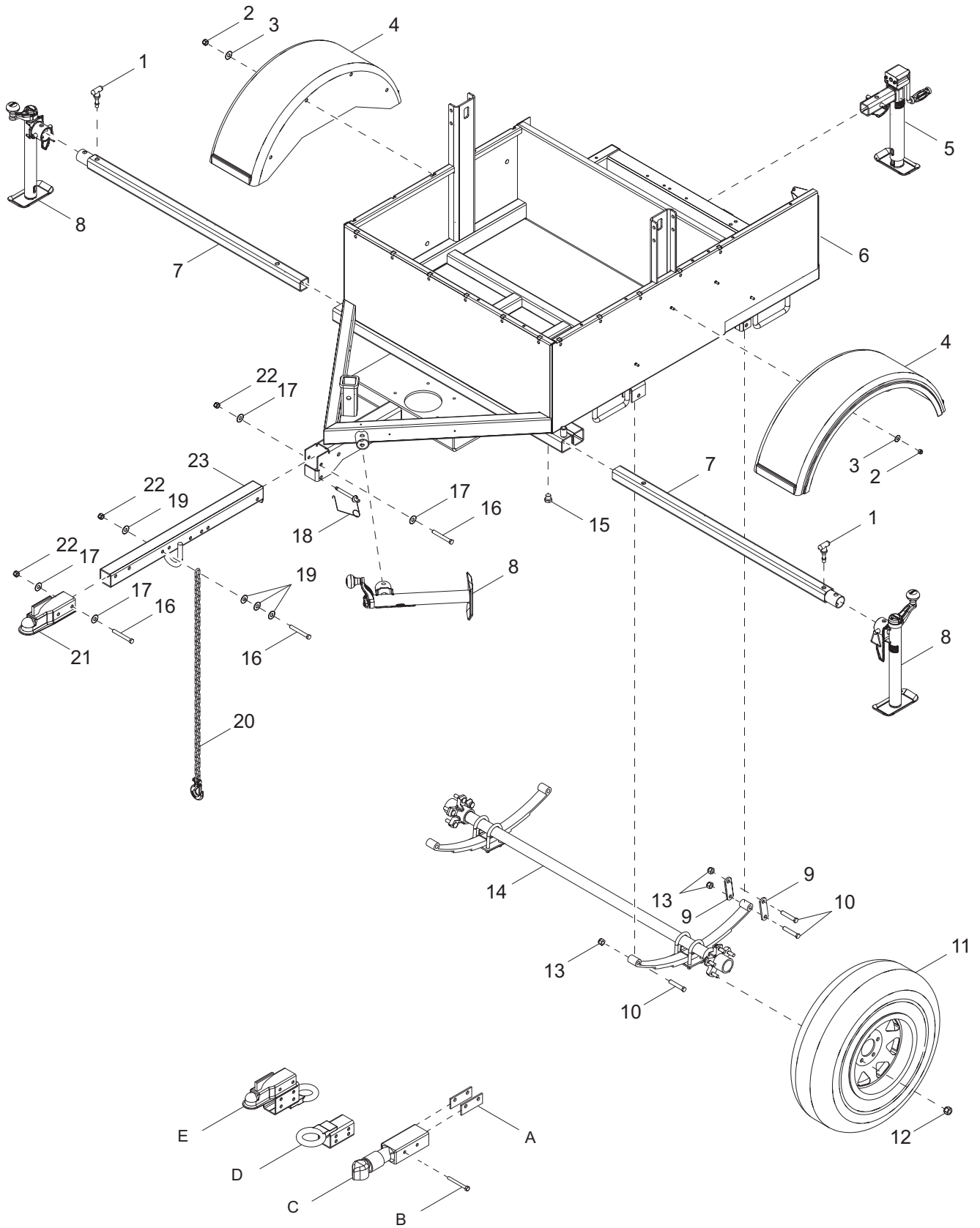

02619

## TRAILER ASSEMBLY

Item	Part No.	Qty	Description	Notes
1	36890	2	Handle, spring pin	
2	60784	8	Nut, .312-18 nylock, SS	
3	60340	8	Washer, .312 flat .875/.040, SS	
4	11381	2	Fender, plastic	
5	72021	1	Jack, side wind, 2000 lb square tube mount	
6	10000022681	1	Weldment, frame	
7	72091ZY	2	Weldment, outrigger	
8	72126	3	Jack, top wind, 1200 lb tube mount, large foot	
9	19637	4	Plate, shackle bracket - 3.125 in.	
10	60503	6	Screw, .562-18 x 3.0 hex, G5	
11	15540B	2	Wheel, ST205/75R-1598 lb.	
12	60096	10	Nut, .500-20 lug, G5	
13	60504	6	Nut, .562-18 locking hex, G5	
14	13131	1	Assembly, axle	
15	60498	1	Fitting, square plug .750NPT	
16	50215	5	Screw, .500-13 x 4.0 standard hex, G5	
17	60309	4	Washer, .500 flat 1.060/.090	
18	33943	2	Pin, locking .500 x 3.50	
19	60416	8	Washer, .500 flat 1.375/.090	
20	23367	2	Chain, safety - 7800 lb.	
21	16830	1	Coupler, 2.0 ball / 2.50 channel	
22	62221	5	Nut, .500-13 nylock, G5	
23	17969B	1	Weldment, tilt tongue	
--	69811	1	Harness, trailer - rear	
--	10264	1	Harness, trailer - left	
--	10265	1	Harness, trailer - right	
--	14129	1	Harness, trailer - main	
<i>Hitch Options: (if equipped)</i>				
A	12155B	2	Spacer, coupler	
B	60376	2	Screw, .500-13 x 4.50 standard hex, G5	Attaches item D
C	16835B	1	Weldment, lunette ring - 3.0 x 1.0 ring/2.50 tongue	
D	34792ZC	1	Weldment, combo hitch - 2.50 tongue	
--	50215	2	Screw, .500-13 x 4.0 standard hex, G5	Attaches items A - D
--	60309	4	Washer, .500 flat 1.060/.090	Attaches items A - D
--	62221	2	Nut, .500-13 nylock, G5	Attaches items A - D
<i>Adapters: (if equipped)</i>				
--	65465	1	Adapter, flat 4 to round 7 spade	
<i>Tandem Tow: (if equipped)</i>				
--	72164	1	Harness, tandem tow	
--	63308	3	Screw, 10-24 x .750 pan Phillips, SS	
--	60067	3	Washer, #10 flat .435/.060, SS	
--	60061	3	Nut, 10-32 nylock	

# AXLE ASSEMBLY

---

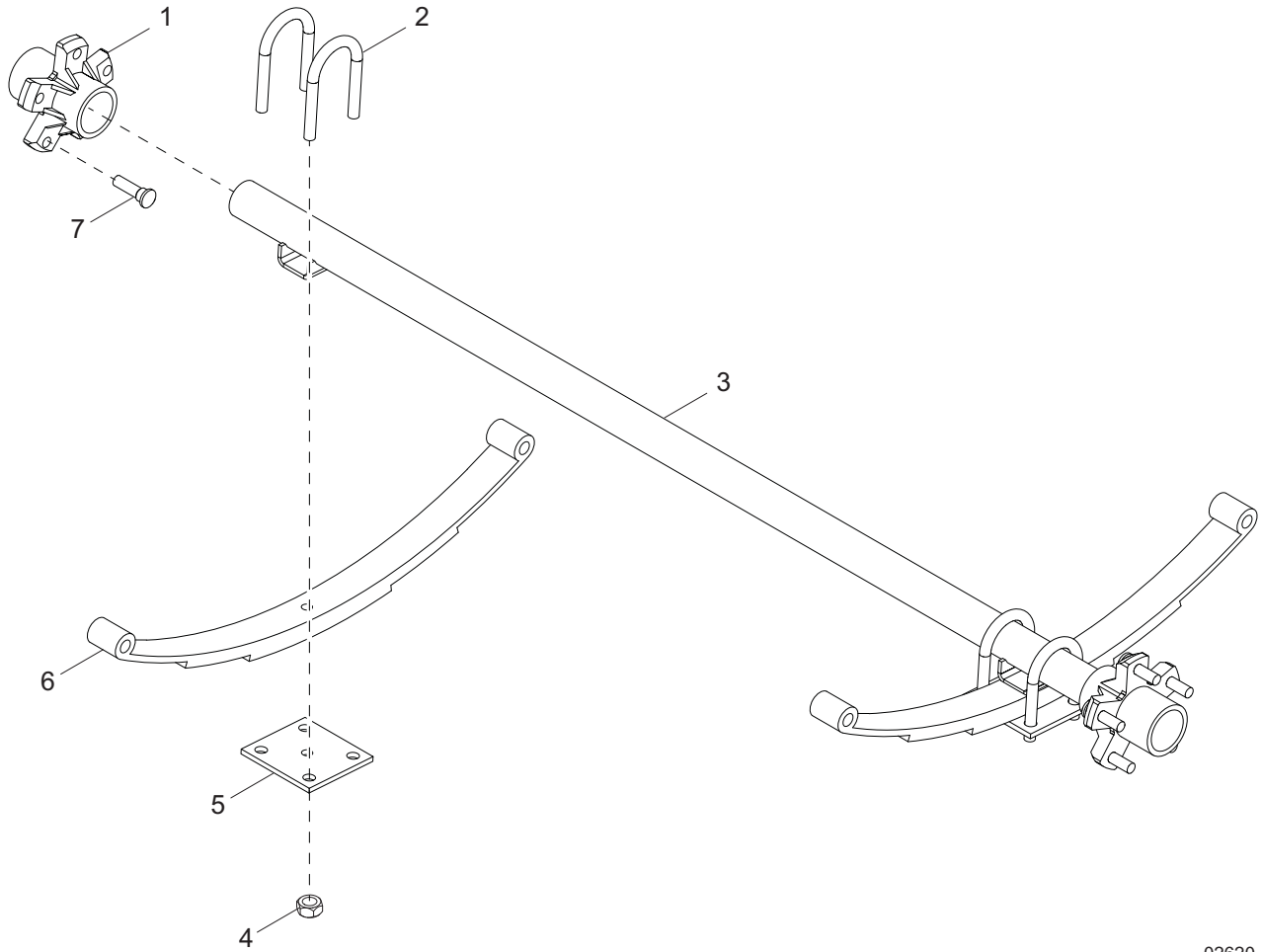

02620

**AXLE ASSEMBLY-**

---

<b>Item</b>	<b>Part No.</b>	<b>Qty</b>	<b>Description</b>	<b>Notes</b>
1	11100	2	Hub w/races	
2	11201	4	U-bolt, 2200 lb.	
3	11385	2	Axle, 2200 lb.	
4	00000	1	Nut,	
5	11202	2	Plate, tie 2200 lb.	
6	16679	2	Spring 25.00inch - 2200 lb.	
7	-	10	Studs	included with 11100

# RECOMMENDED SPARE PARTS - ENGINE AND SERVICE KITS

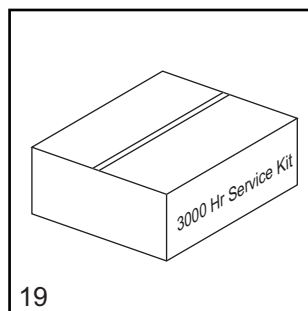
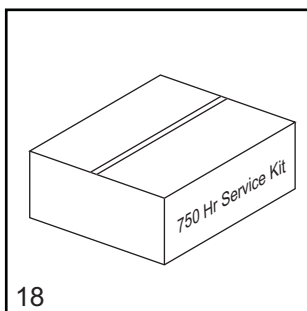
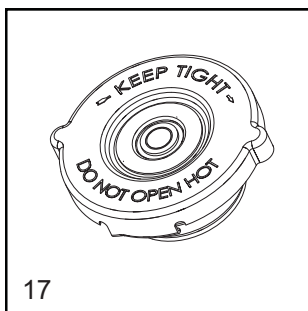
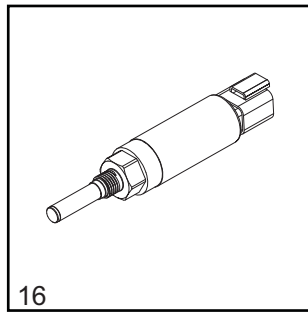
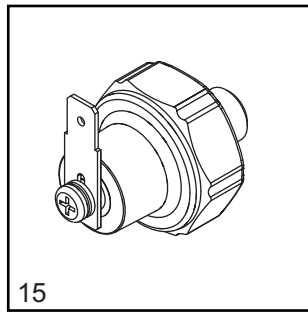
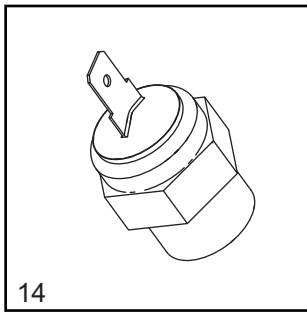
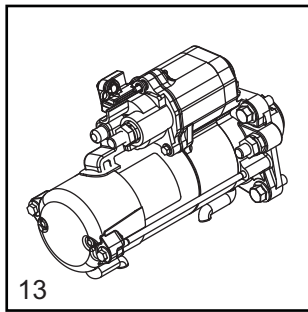
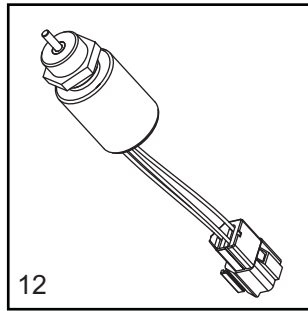
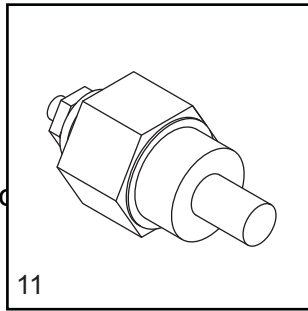
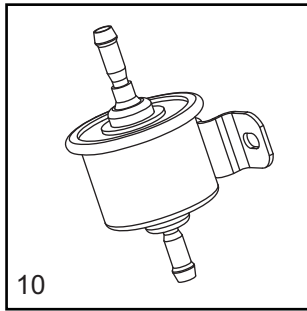
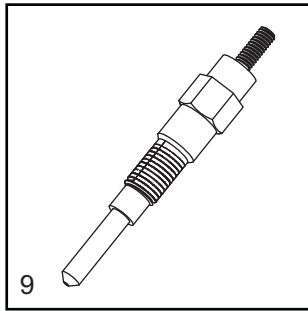
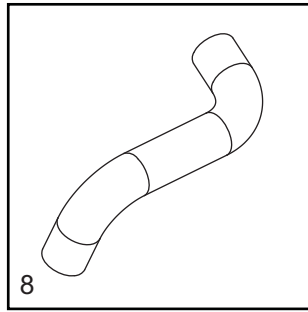
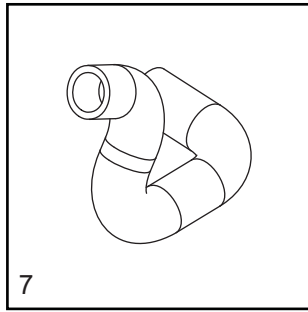
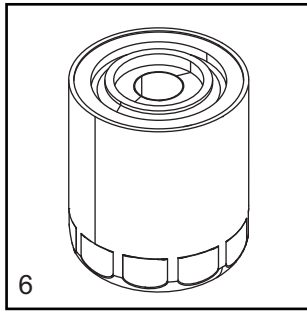
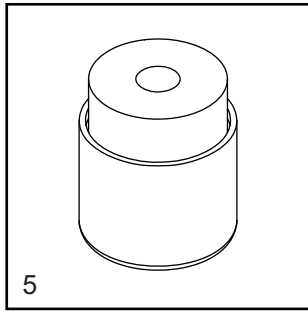
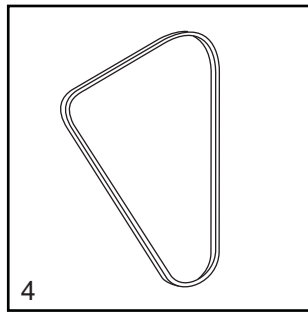
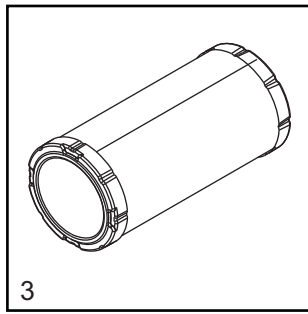
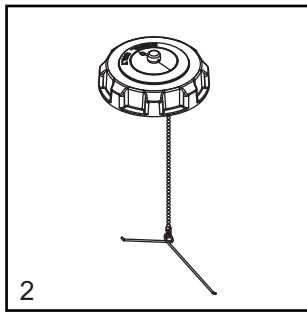
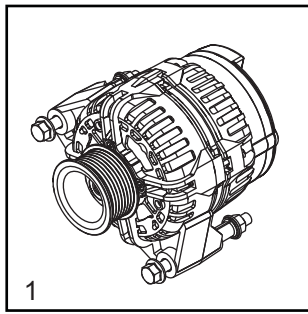

## RECOMMENDED SPARE PARTS - ENGINE AND SERVICE KITS

---

### ENGINE

1. Alternator .....	72129
2. Cap, fuel tank with lanyard .....	16326
3. Filter, air (element).....	16444
4. Belt .....	72177
5. Filter, fuel .....	10000023037
6. Filter, oil .....	70124
7. Hose, radiator - lower .....	16688SRV
8. Hose, radiator - upper.....	36977SRV
9. Element, glow plug .....	16693SRV
10. Pump, fuel .....	13278SRV
11. Sender, coolant temp .....	12873
12. Solenoid, fuel shutdown .....	16683
13. Starter .....	16833
14. Switch, coolant temperature .....	16678
15. Switch, oil pressure .....	16677
16. Switch, NC fan and intake heater .....	10000008988
17. Cap, radiator.....	19219

### SERVICE KITS

17. 750 hour kit.....	10000035816
-----------------------	-------------

Includes: Primary Air Filter 16444, Fuel Filter Element 10000023037 and Oil Filter 70124

18. 3000 hour kit.....	SK335
------------------------	-------

Includes: Engine Belt 72177 (2), Air Filter 16444 (4), Fuel Filter Element 10000023037(4), and Oil Filter 70124 (4)

# RECOMMENDED SPARE PARTS - ELECTRICAL

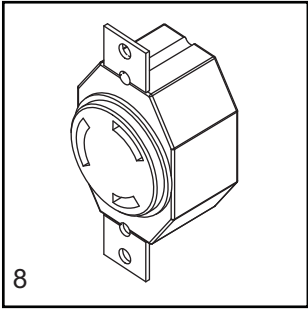
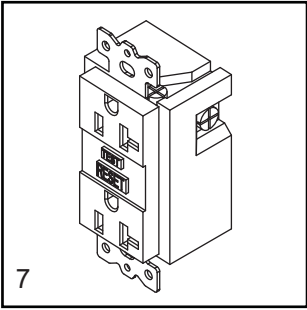
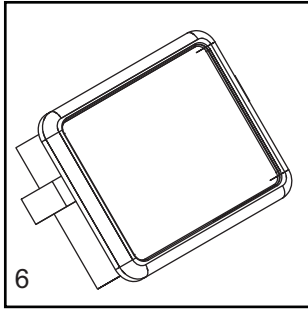
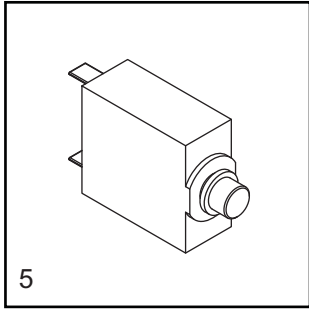
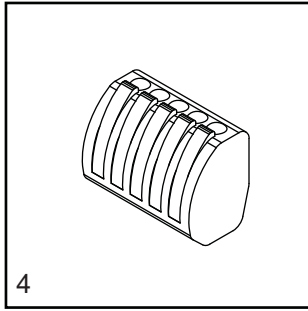
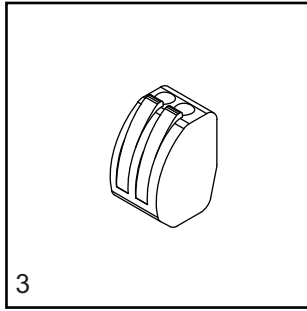
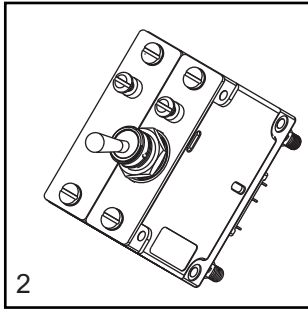
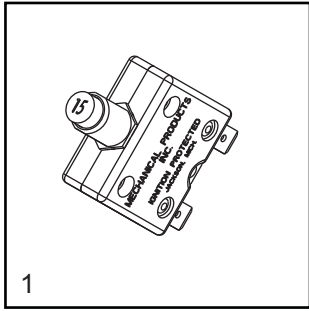



## RECOMMENDED SPARE PARTS - ELECTRICAL

---

### ELECTRICAL

1. Breaker, 15A, 120V, 1 pole, push button, 8kW .....	65849
2. Breaker, 30A, 250A, 2 pole, 6kW .....	36975
3. Connector, 2 position .....	66100
4. Connector, 5 position .....	66102
5. Breaker, 10A DC .....	36937
6. Controller- LED programmed .....	70137
7. Receptacle, 120V/20A GFI .....	14130
8. Receptacle, 240V/30A twist .....	65488

# RECOMMENDED SPARE PARTS - MISC

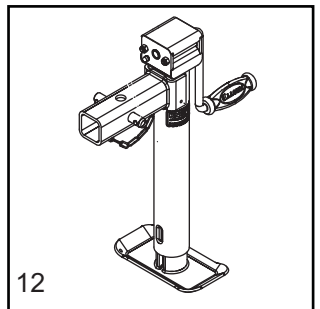
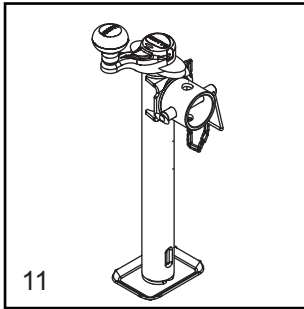
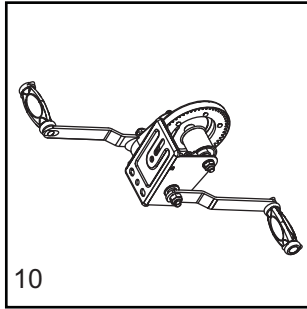
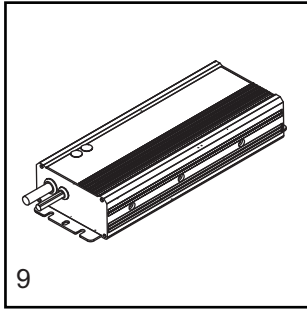
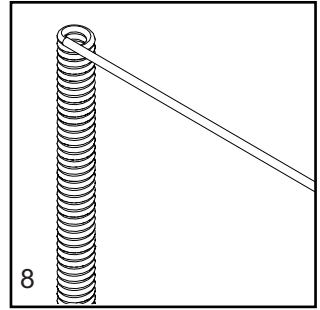
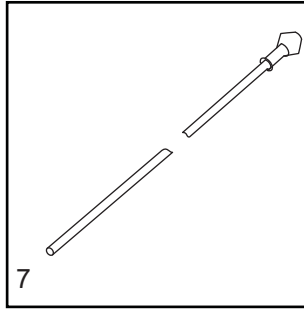
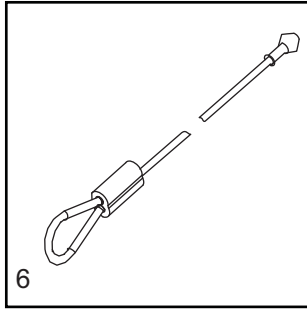
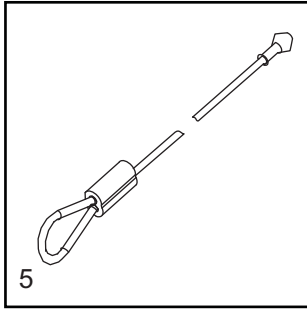
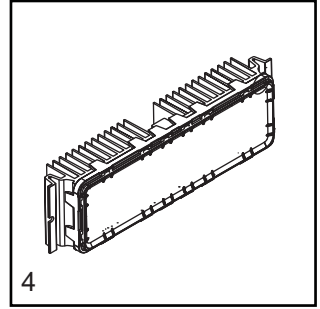
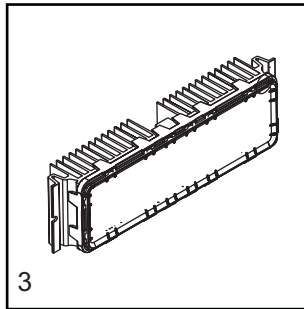
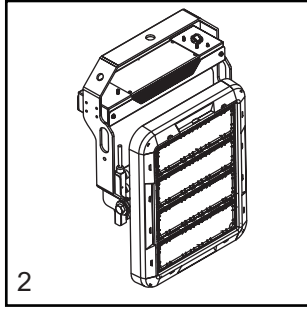
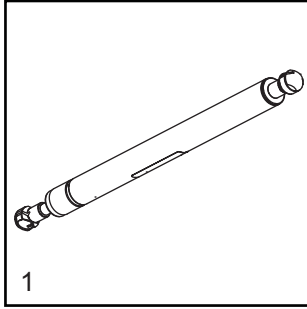

02621

**ENCLOSURE**

1. Gas shock..... 35137

**MAST**

2. Assembly, LED light..... 10000019145

3. Module 60 degree LED..... 10000019170

4. Module 40 degree LED..... 10000019160

5. Cable, 79.75 in ..... 31248

6. Cable, 78 in ..... 31277

7. Cable, 144 in ..... 31247

8. Coil cord ..... 10000035623

9. Driver, LED 30V, 10.7A, 320W ..... 10000019146

10. Winch, manual, includes dual handle ..... 72178

**JACKS**

11. Jack, top wind, 1200 lb ..... 72126

12. Jack, side wind, 2000 lb. .... 72021





Part No. 10000033588 Rev. C 07/23/2019

©2019 Generac Mobile Products, LLC  
All rights reserved.

Specifications are subject to change without notice.  
No reproduction allowed in any form without prior written consent  
from Generac Mobile Products, LLC.

**GENERAC** | **MOBILE**

Generac Mobile Products, LLC  
215 Power Drive, Berlin, WI 54923  
[GeneracMobileProducts.com](http://GeneracMobileProducts.com) | 800-926-9768 | 920-361-4442